



Green Values,



Religion



& Secularism

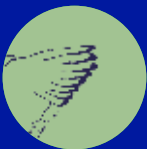

Conversations with
European politicians
and activists

Editors: Nuala Ahern
and Erica Meijers

Noël Mamère

François Mandil

Meryem Almaci

Tina Walzer & Marco Schreuder

Adam Ostolski

Agnieszka Kościańska

Yannis Paraskevopoulos

Giorgos Dimaras

Savaş Çömlek

Nil Mutluer

Mary White

Trevor Sargent

John Barry

Judith Sargentini

Sergey Lagodinsky

Bettina Jarasch



Green



Values,



Religion



& Secul



arism

Editors: Nuala Ahern and Erica Meijers



Noël Mamère:

*Do not rouse the ancient
demons of religion*

22



Meryem Almaci:

*When will you finally
cross that bridge?*

44



François Mandil:

*If you are a Christian,
you simply have to be an
ecological activist*

34



Tina Walzer

& Marco Schreuder:
*Recalling the heyday of
Vienna's Jews*

54

Adam Ostolski:

*What is sacred for us may
not be sacred to others*

62



Yannis Paraskevopoulos:

*Religions are not immune
to social change*

78



Agnieszka Kościńska:

*The spirit of an 'open church'
has faded in Poland*

70



Giorgos Dimaras:

*Greece must separate
church and state*

86

Savaş Çömlek:

*Make space for a colourful
understanding of religion*

94



Mary White:

*I am a small part of
the great sea of life*

112



Nil Mutluer:

*Secularism in Turkey
is not freedom from,
but control of belief*

102



Trevor Sargent:

*Practice what
you preach*

122

John Barry:

*What are the stories we
are telling ourselves?*

130



Sergey Lagodinsky:

*The Christian idea of
religion prevails*

146



Judith Sargentini:

Live and let live

138



Bettina Jarrasch:

*Develop a different
Green Party culture*

156



Afterword

167

About the Authors

172

Imprint

174

Introduction



Religion and politics have much in common. They share the longing for another world, one in which peace and justice will reign. They also share the dangers of this desire: the temptation to force their own imaginative order onto others. Both religion and politics have to find a way to deal with the tension between the actual world and the world as they imagine it should be.

The fact that they do this in very different ways is part of the explanation why religion and politics, by definition, have a difficult relationship. Modern political movements have roots that go back one or two centuries at most, whereas religious traditions have much older sources. However, this doesn't discharge either of them from the task of interrogating and reinterpreting their traditions in the light of new challenges.

In this publication, Green politicians from different European contexts reflect on the relationship between politics and religion, both in their own lives and in society.

Religion in public life

Since the 9/11 attacks in the US, international scholars from different disciplines have increasingly focused their attention on the role of religion in politics and society, while political parties have been behind the curve.

In the last decades, the relationship between religion and modern society has shifted. On the one hand, especially in Western Europe, secularism has become mainstream. No single religious tradition can command a majority in society; religion is more diverse and not always clearly organised. Muslim and Christian immigrants have a different approach to religion compared with Europeans, both Christian and secular. A more evangelical belief is gaining ground among young people in Europe, while the ecumenical movement, with its interest in tolerance and pluralism, seems to have lost momentum. In addition, the quest for a personal spirituality has created a kind of privatisation of religious belief, which is very different from the former place of religion as a shared cultural experience. The uncertainties of our times, however, still make people long for another world and for something to cling to in times of despair, and religious communities offer both practical help and a sustaining sense of belonging, particularly to those who are desperate and vulnerable.

At the same time, religion plays a larger role in politics and

society than it did before 2001. There have been fierce debates on issues such as ritual slaughtering, homosexual teachers in schools, the wearing of the headscarf in public institutions, and the relationship between Islam and terrorism. These debates are seldom about religion alone; the social and economic position of the communities involved; the relationship between the majority and minorities in society and international power-constellations all play a major role. That makes it even more important to look more precisely at the role of religion within these conflicts. Are we talking about the relationship between belief and politics, or is the relationship between church and state at stake? Who profits from a certain position or argument, and who has to bear the consequences? Are all the communities involved part of the debate?

To avoid falling in the trap of populist parties, which have a tendency to play off the freedom of religion against other basic rights, leading to a polarisation between different groups in society, it is essential that political parties engage properly in questions concerning the relationship between religion and public life in Europe today.

Split image

Green Parties have their own role to play when it comes to religion and society. Their relationship with religion and religious communities is ambiguous. Some Greens hold strong religious beliefs, while others are convinced atheists. There are even ideas about the development of a Green religion, in which the earth is the central figure, not human beings. Greens and religious communities share ideas such as solidarity, peace and justice, and often meet together with churches and their members when it comes to the protection of refugees, for example. Environmental movements, such as the Climate Justice movement, has strong ties with the religious idea of the integrity of creation. Thinkers like the American transcendentalists Ralph Waldo Emerson and Henry David Thoreau and theologians like Ivan Illich and Jacques Ellul have influenced the development of ecological thinking.

While Green thinking has deep roots in European philosophy and theology, the Green Parties were only founded in the second half of the 20th century, in Central and Eastern Europe often even after 1989. Green Parties are usually more libertarian than the Social-Democratic, Socialist and Communist Parties, which makes

them even more sceptical about religious communities. But they are also more critical of modernity than their left-wing counterparts; they identify the failures and dangers of industrial society, and the cult of progress and economic growth. The Green critique of modernity therefore approaches a religious critique of humanism, understood as humans being the measure of all things. Green values are profoundly critical of the idea of the isolated individual freely contracting with other isolated individuals as the basis of social and economic life, and see this as a dangerously destabilising liberal mythology with little basis in reality. One of the crucial debates among the Greens today is about the question how much we trust technological innovations to install a circular and sustainable economy. Some believe in a rational and scientific approach, others think it is impossible to address the issues of climate change and loss of biodiversity by science and government alone.

This debate mirrors a more fundamental question of how Greens see humanity. In general, they tend to stress more the relational aspect, seeing human beings as part of a larger whole (not necessarily in a transcendental way), living in connection with each other and with their ecological environment. As political parties though, they do not really act accordingly, as the Dutch philosopher Ger Groot observed after reading the interviews in this publication. He noticed that Greens have little room for the contemplative side of life; they very quickly focus on the responsibility to act, looking at wrongs which must be righted. The Greens have a split image of the human being: people are part of a bigger constellation but, at the same time, they are the masters of that same constellation (cf. *de Helling*, winter 2015, p.10).

As a consequence, perhaps, Greens also have a split relationship with religion. In spite of much common ground, religion is often seen as something backward and old-fashioned, that hinders the liberation of individuals and society. The ‘secularisation thesis’ still has a grip on the Green movement, as it has on the left-wing parties. During the 1960s and 1970s, left-wing intellectuals expected religion to disappear from society in the long run. Secularisation and emancipation would make religion superfluous. It has been pointed out by many scholars that this concept no longer makes sense. Religion shows no signs of disappearing from modern life, but it does manifest itself differently – on the one hand, in a more

political way (the Islam debate) and, on the other hand, in non-institutionalised forms.

At a loss

How do Green Parties deal with these developments? On a European level, the debate on the changing role of religion within our societies seems to be avoided by the Green movement altogether. In the *Green Common Manifesto* for the European Elections of 2014, the word 'religion' is mentioned only once, as a ground for discrimination that the Greens do not accept (p.9). Islam and Christianity are not mentioned, neither are other religions. This silence might have to do with the fact that most Greens do not see any direct line between political opinions and religious texts and other sources. This 'neutrality' comes from the conviction that everybody can join the Greens, as long he or she supports Green ideas. In this way, religion is in fact regarded as a private matter. It is exactly this attitude we want to challenge.

However, despite its absence of the theme in the *Manifesto*, Greens seldom consider religion a completely private issue nor want to exclude it from the public sphere. This must mean a consideration of such questions as: how to deal with the unease caused by the fact that minorities, whose rights Green Parties want to defend, hold views and practices that exclude other minorities, like homosexuals? How to defend the freedom of religion when it collides with other basic rights? How to find allies within religious communities without ceasing to criticise that same community? What is the Green stance when it comes to ritual slaughtering? How are Greens to think about the hijab and the burqa? And on a more fundamental level: how is religion to be defined? Is it a set of convictions, a feeling of dependency on something or someone bigger than ourselves, or is religion about community, rituals and behaviour? Who has the power to define religion, and what consequence does this have for minorities? How to discern between the questions of church and state on the one hand and, on the other, the public arena where religious contributions can be welcomed like others?

One thing is certain: if Greens do not start to debate these questions among themselves, they will be at a loss every time an issue related to religion, in one way or another, comes up and they will continue to react in an arbitrary and topical way, without a coherent view or an awareness of the debates and dilemmas involved.

With this publication we want to work towards a more coherent debate within the Greens on the changing role of religion in society. It is not meant to give answers or to make concrete political proposals. We want an open dialogue within the Parties and within the European Green Party. We are convinced such a dialogue will help the Greens to move forward in seemingly unrelated issues like immigration, climate change, international affairs and the growing inequality within society. It will also help the Greens to take a clearer stance towards certain religious groups in society, to react better to the radicalisation of young Muslims, to sort out conflicts between religion and emancipation, and to give space to the religious traditions within its own ranks. Listening to the different experiences and practices will bring a better understanding of what we do and do not share as Europeans, since religion brings us within the capillary system of our European societies.

Party culture

Therefore, as a starting point, a team from six Political Foundations in Europe interviewed sixteen Green activists and politicians from nine different European countries (in order of appearance): France, Belgium, Austria, Poland, Greece, Turkey, Ireland, Northern Ireland, the Netherlands and Germany. After having shared our own views and positions regarding religion, we decided on a set of questions we considered important to start our dialogue. They included the definition of religion; the interconnectedness of religious or secular values and political attitude; the role of religion in the public forum; conflicts between fundamental rights, such as the freedom of religion and the principle of sexual and gender equality; the role of Islam in Europe; whether religion is a source of inspiration or an obstacle for Green politics.

The last interview in this publication has an extra dimension. Bettina Jarasch, Chair of the Commission on Philosophy of Life, Religious Communities and the State (founded by the German Greens in 2013), argues in favour of a different way of debating topics so closely linked to people's identity. She proposes a discussion across the Party, without specific proposals or decisions. The resulting picture can already make clear where the sensitivities lie and what the dilemmas are. In that way, difficult questions can be discussed, even if it is impossible to take an official stance. This could offer a way for Green Parties in Europe, as well as the Green

European Party, to discuss the topics presented in this publication. We invite all readers to participate in this dialogue.

Hope

As editors, we would like to thank everybody who already engaged with us in this dialogue. In the first place, our colleagues from the Green Foundations who chose their own participants and who conducted a great many of the interviews, including translations into English. We also thank the Green European Foundation, especially Aurélie Maréchal and Beatrice White, for their interest in the project and their practical help. We are grateful for the excellent work of the translators involved in this project, Robert Dorsman (translations from Dutch) and Anna Collins Mani (translations from French), and of Ann O'Conarain, who did the proof-reading. We also like to thank Barry Ahern and Philippe McIntyre for their warm support.

We were pleasantly surprised that many people showed interest and shared their stories in our workshop during the Council of the European Green Party in Lyon, France. The terrible attacks in Paris, which occurred on the same night, undermine dialogue on these topics but at the same time make it more urgent; we are convinced that the best way to overcome conflict, fear and alienation in our European cities is to exclude none from dialogue, and to listen to all our visions, dreams, hopes and fears with respect and critical engagement.

At the end of this introduction, we would like to introduce ourselves as the initiators of this dialogue that is just beginning, presenting a few quotes from our own on-going conversation on the theme.

Nuala Ahern: I think that religion as a force in the world today is becoming stronger, not fading away. In the western world I think this has something to do with the search for values in the face of a destructive and seemingly unstoppable consumerism. I had a liberal upbringing, I did not experience a repressive religious family and so I am open to religion in a broad sense as a positive containing force. I think that the inspiration and energy of religious values can be a great ally in the crisis of climate change and loss of biodiversity.

I also see a connection between political events, such as the Euro crisis, and religion and culture. These deep cultural differences between, let's say, the Protestant north, the Catholic south and

the Orthodox east are very striking and do not help us to listen and understand each other. Of course it is overlaid by politics and economics, but cultural seems to me to trump economics and logic, and can stop us finding positive solutions.

My own religious practice is about observing the pilgrimages that have existed for a very long time in Ireland. On the Sunday following the Good Friday Agreement in 1998 we climbed Croagh Patrick in County Mayo as a way to express our joy. To walk this holy mountain at that Easter-time with many others in a pilgrimage gave a sense of renewal and redemption. It clarified for me that, when something really important happens, it is helpful to celebrate in a ritual way. Religion is not only in my head; it moves me in a feeling way to action. It brings me in touch with the natural world and a sense of the sacred at the same time.

Erica Meijers: I see religion basically as a way to connect with something bigger than us and the recognition that human beings are not the centre of the universe. It can be both creative and destructive. During my studies I learned about the force of Christianity for oppression and for liberation from black and liberation theologians. My political engagement is very much related to my Christian belief. As a Jew, Jesus was engaged in creating a radical change during his own lifetime and was executed brutally. His resurrection means a victory over evil, maybe more than a victory over death. It is unacceptable that there should be no justice for the victims of our world and that evil and death should have the last word. Resurrection to me is not some supernatural miracle; it is a promise that we are not subject to evil and death *without hope*.

I come from a Calvinist background. My parents were part of the Dutch movement in the 1970s that wanted to renew the church. My father became a humanist; he refused the god he grew up with, for whom you were always guilty. When I studied Calvin in Strasbourg, I discovered that grace is at the heart of Calvinism, but I have also met the ugly face it later became. I believe in the poetic power of words and stories; the stories of the Bible have accompanied me all my life.

Nuala Ahern: "Poetic truth is basic to my concept of religion. Poetry blows the heart open when the mind has snapped shut, to paraphrase the Irish poet Seamus Heaney."



Nuala Ahern and Erica Meijers – December 2015

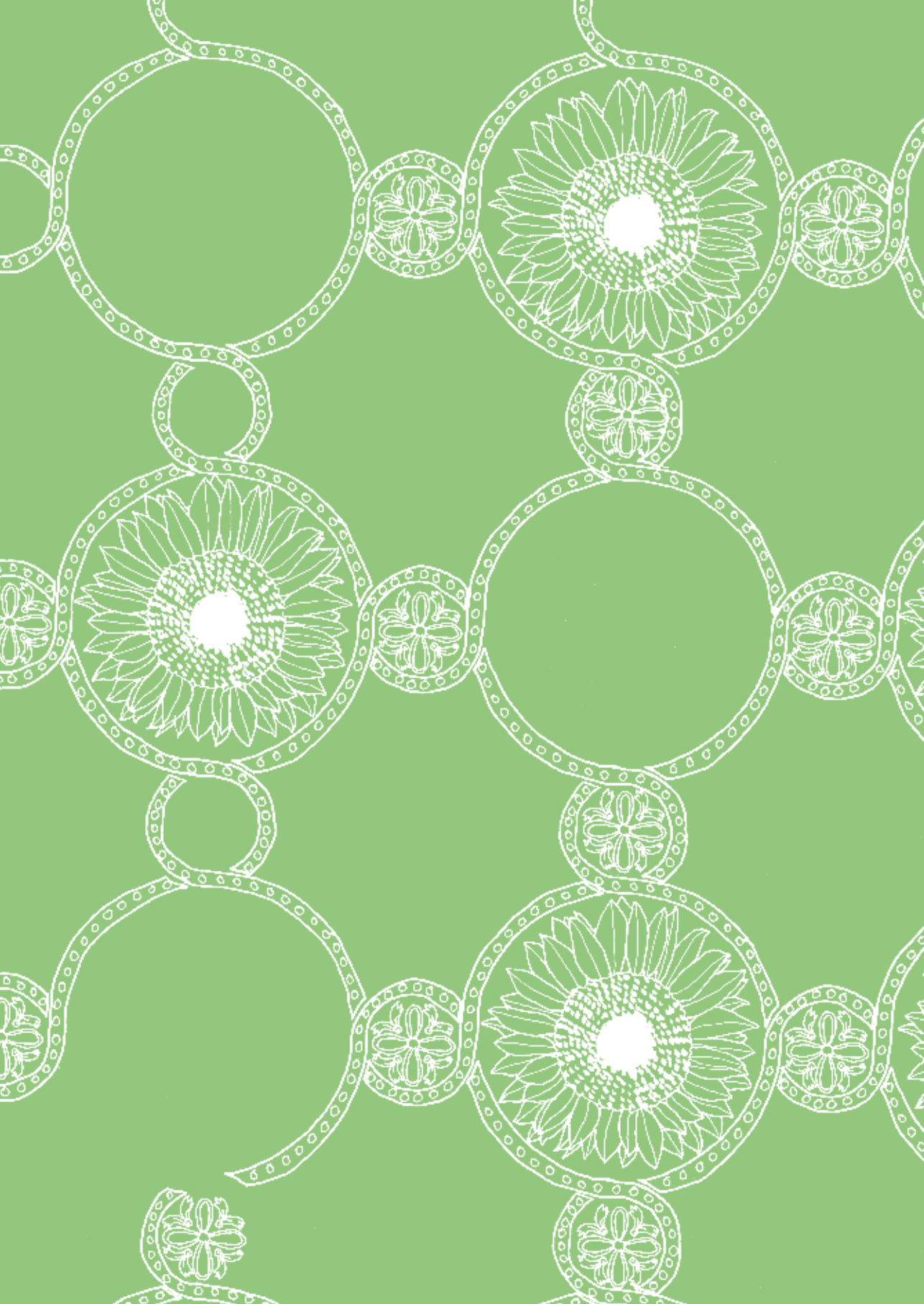





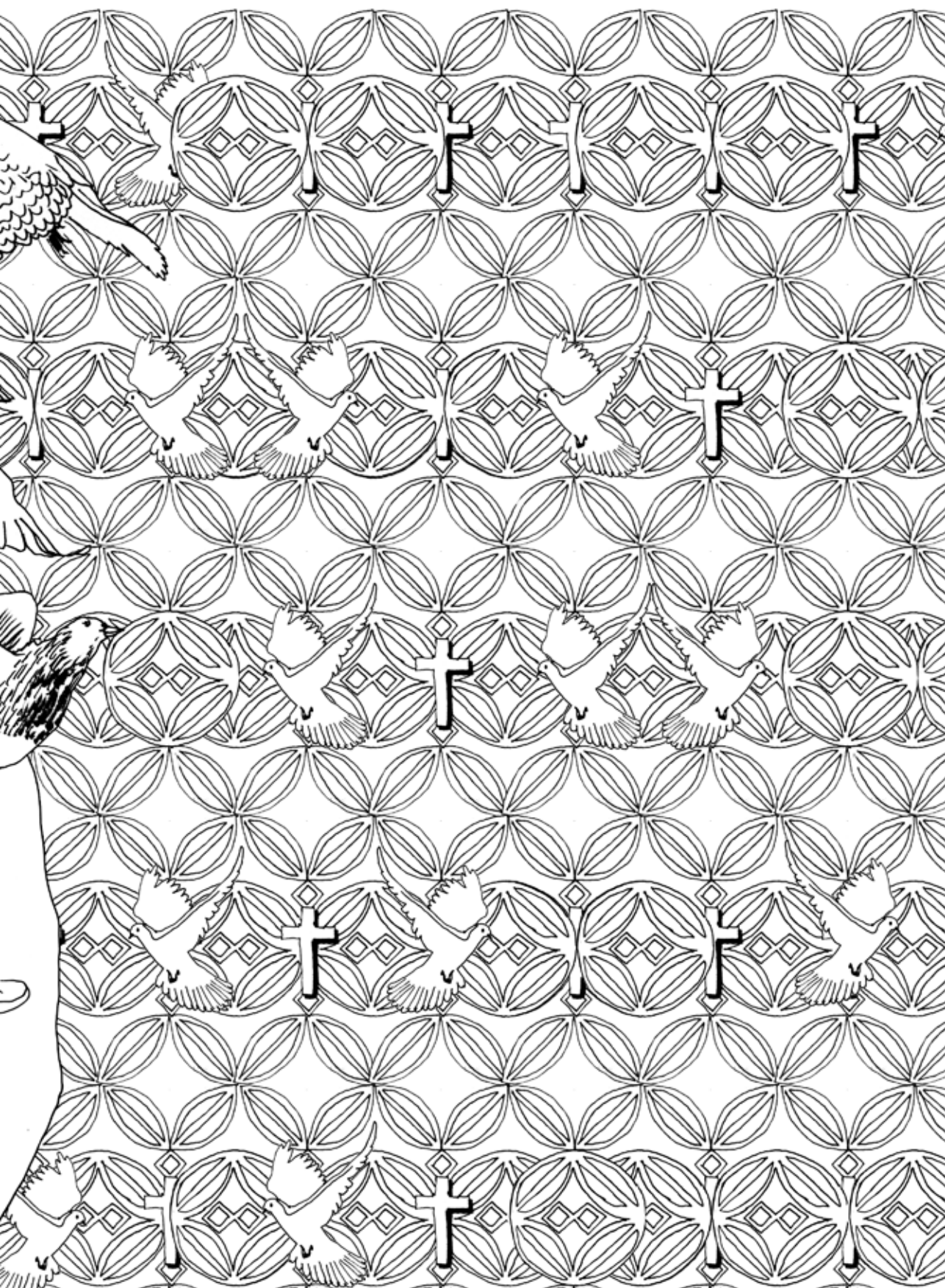

Noël Mamère:

Do not rouse the ancient demons of religion



Noël Mamère (born 1948) was a journalist prior to becoming a politician. He became a household name in France in the 1980s as a presenter of the daily news on Antenne 2 (one of the top French television channels and the direct predecessor of France 2). He has been Mayor of Bègles in the south-west of France since 1989 and a Member of the National Assembly (French Parliament) since 1997. He ran for president as a Green candidate in 2002, a campaign in which he recorded the best result of any Green candidate for the position, gaining 5.25% of the vote. He has written or co-authored more than a dozen books. His latest work *Changeons le système, pas le climat* was published by Flammarion in 2015.

You were born on 25 December and were named Noël (French for 'Christmas'). Does that naturally create a special connection to religion?

A birthday is not something that you chose, but if you are born on December 25th and your parents name you Noël, it is a clear indication of their strong faith. This was the case with my parents. I was born into a Catholic family which practiced their faith with great passion and a significant portion of my family – this is important – still believes and practices with great zeal. I do not.

Could you describe how religion influenced you?

My parents raised me in religion and the schools that I attended were parochial schools run by priests, nuns and, in part, Jesuits. Therefore, I did not experience other types of learning institutions

until university in 1968-1969. I attended parochial schools where we had religion as a matter of course, Mass every day, and where we would go to confession. Of course we were baptised, took first communion, solemn communion, confirmation, etc. Until the age of 18, I was a strong believer and practised regularly. As an altar boy, I advanced to what we referred to in French Catholic religious jargon as ‘pot de fleur’, the boy who wears an alb, and made my way up to rituals at the altar. It was very important to me. It meant the world to me; it was the world of my parents, of my school.

I began to open my eyes the day that I found myself in a boarding school around 150 km from my home. The staff there were very strict; we were not allowed to leave without someone accompanying us. The school was known for being very religious and very severe. Then I went to university in Bordeaux, where I discovered a world that was not exactly like the one that I had known until then. There were people from other religions, and these *religions of books* could also enrich. I also discovered, at the same time, that it was possible to live without religion and to develop humanistic values. I learned that there were atheist and agnostic philosophers and thinkers, who could also contribute. I suddenly felt as if I had – until 18-19 – lived in a narrow world. That takes nothing away from the respect and love I have for my parents and for the values that they imparted to me.

There were two great influences on me in Bordeaux. The first was Jacques Ellul a protestant theologian and philosopher. I took his history of political thought courses and his course on technology. And another professor who was his close collaborator and we referred to them as the “personnalistes gascons” [Ellul and Charbonneau had their own, more revolutionary version of personalism, a French political philosophy from the thirties, which was called after the region they lived.]. – I would often go to Bernard Charbonneau’s home; I conversed regularly with Jacques Ellul. It was in this group that I dived head-first into the Green movement in the 1970s. I had everything to learn in this unfamiliar movement, its way of thinking, its reflexive dimension that was very self-critical. None of this existed in the Catholic Church. They taught me about the culture of doubt. Religion leaves its mark, of course, and it will for the rest of my life.

Could you give me your personal definition of religion?

Religion: is it a cross that one bears in the fear of God or a crutch that we use to accept our finite nature? I do not believe that those who have faith are weak, but I do not believe that it is the best approach to fighting this feeling of our finite nature. Those who were raised in religion must be able to extract themselves from this way of thinking and accept that it is through the actions of people we will be able to accept our human condition. I have made that effort.

Ecology has multiple sources, both spiritual and materialistic. Does the presence of religion in public debate inform political ecology and the implementation of ecological policies?

Ecology does not come from a single story; it comes from several movements, which often take inspiration from religion. For example, it is influenced by the transcendentalist movement of Ralph Waldo Emerson in America in the 19th century, who believed in a certain harmony between mankind and nature. This was directly inspired by the Protestant religions. Jacques Ellul, as a Protestant theologian, is a part of the ecological thinkers who never mixed religion and ecology, and who always considered that the history of relations between people and nature is not an eternal love story has, but rather a struggle. It is the French school of thought that I relate to most.

Contrary to what some elements of the Green movement would have you believe, nature is not very welcoming. Nature is hostile to humans, who, from the very outset, have tried to tame nature. Currently, the problem is not the taming of nature but taming the taming.

There is a religious element to it, as stated by the German thinker and ecologist Günther Anders. He referred to it as the "Promethean shame." Man thinks himself God, believes he is nearing him, but he will never succeed, because as far as I am concerned there is no God.

Political ecology is definitely one of the schools of thought that is most influenced by religions. It is not the only one of course. Marxism, the religion of progress, takes inspiration from religion. It is a Messianic project for a world where everyone would be equal and in which there would be no more war. From this standpoint, ecology and communism are two variations of political thought

that is influenced by religion. Modern ecological movements, like those originating in Latin America, have also taken influence from religion. Liberation ecology is inspired by Leonardo Boff.

I am wary of any approach that mixes a religious *modus operandi* and a secular one: the spiritual should never be mixed into political action. I fight anything that would try to bring religion to the rescue of a political cause. On this point, I disagree with Nicholas Hulot. I read his appeal to religious leaders in *Le Monde*. That they are concerned with the climate-change threat to the survival of mankind, why not. But, we should not turn to religion for our salvation. The question is whether or not mankind will be able to continue to live decently on this planet. If that is what we are aiming to achieve then we are dealing with – not a religious issue – but a question of solidarity. In fact, the slogan of ecologists has been: “we only have one Earth”. Certainly religions preach solidarity, but not always.

Having said that, this is not just the case for ecology. Clearly at times there is an inevitable convergence between political projects and religious projects. When priests open the doors of their parishes to undocumented immigrants, there is an obvious meeting point between that effort and the effort of human rights activists. That does not, however, mean that we will turn to religion to fight our fight. If some religions believe that our cause is right, and they join us, why not? At the same time, however, a clear distinction must be drawn between the spiritual and the acts of human beings, the secular realm. Religions have wrecked such havoc. We should not rouse ancient demons.

Ellul maintains there has been a shift in the sacred from religions to the technological domain. Isn't Ecology seeking to desacralize the technological?

Your assertion regarding Ellul is not incorrect. Yet, when you read *La technique ou l'enjeu du siècle*, (The Technological Society) he does not directly analyze technology as a replacement for religion. He speaks of a religion of progress. He is not the only one, Huxley did also. What Ellul stated, and what in my opinion is right, is that human progress is not necessarily equal to technological progress and if we do not keep it in check it could turn on us and effectively impinge on our freedoms. The recently adopted Intelligence Bill in France

is an illustration, it is a victory for technology over our freedoms, I voted against it in the National Assembly. At the same time, we tend to compare triumphant technology to a religion, because we have an example from the 19th century. At that time there was a boundless admiration for progress. Ecologists were formed via their criticism of industrial society; they were children of the post-industrial society. Their critical contribution was to question the meaning that had been attributed to progress. That is why we struggle so to find common ground with communists or socialists who are the heirs to the major political families who are built on the cultus of progress. For ecologists, the search for growth alone is not progress. Is cloning a human being progress? Do GMOs and the irreversible manipulation of living organisms constitute progress? This is not progress as far as we are concerned.

When human beings believe that they can control and tame everything, they are adopting a 'Promethean' approach. There is an idea developing around transhumanism that the convergence of nanotechnologies, biotechnologies and cognitive sciences will result in the enhanced human. This is a Promethean idea that purports to resolve the problem of the three great necessities: birth, suffering, death: birth through new reproductive techniques; suffering by easing pain; and death through the quest for immortality. To a certain extent it equates to playing God. It is a mad dream, completely scientific with a religious element, but that effectively puts us at the mercy of technology. Voluntary Servitude as the French philosopher from the 16th century Étienne de la Boétie called it. I made a documentary on the subject on Arte in 2012, "A World without Humans".

Some religious doctrines formulate a refusal of man assuming the role of God; your critical analysis is quite close to that, isn't it?
 Not only religion formulates this criticism. Ecologists believe in auto-limitation, especially useful when it comes to man's insatiable hunger for energy. For some, for many, shale gas is the future. Meanwhile, we are currently faced with an urgent need to decarbonise our societies. To effectively create a paradigm shift, even with millions of tonnes of gas under our feet, we have to refrain from using it. When we moved from the Stone Age to the Iron Age, it was not for a lack of stones.

Was this 'faith' in technology the reason why we have incessantly pushed back the limits of man?

Exactly, it is what we refer to as geo-engineering: so we can continue to pollute, deplete the planet and find the technical means for business as usual. For example, the French minister for ecology, Ségolène Royal boasts of the pros of the electric car. The problem with cars cannot simply be distilled down to changing a combustion engine for an electric one. The real problem is how the car is used. In 1967, Bernard Charbonneau wrote in *L'Homme auto* that the belief in building cars meant building societies. Today, the car issue boils down to car-sharing and car-pooling and not changing the engine type, because even electric cars must be powered and that means nuclear plants.

In your opinion, what are the main challenges that European societies face today vis-à-vis religion?

It is clear that European societies are grappling with one religion in particular: Islam. France's colonial history means that it is currently the second religion in France. Colonisation gave way to asking those that were previously considered 'indigenous' to contribute to the wealth of our country. These individuals practised a grass roots and very modest form of Islam. They struggled to adjust. They were forced to practise their religion underground. Then, they brought their families to France and flourished, like others. Suddenly those previously considered clandestine, were going to have to be accepted into society. Today, European societies are faced with a contradiction. They are struggling to accept the increasing place that the religion of the formerly colonised is beginning to take in society.

In France, we refuse to accept the role that we played in the past and refuse to accept that Islam cohabitates with Judeo-Christian religions. This failure to acknowledge the elephant in the room has spurred radicalisation. Fascists exist in all religions. They slip through the cracks and today are used for fear mongering by those who reject Islam. It serves as a basis for saying that Islam is not compatible with democracy, as the former president Nicolas Sarkozy did on May 31st, 2015 on the day of the announcement of his new political party formation.

It is ludicrous. The Arabs were in Andalusia for seven centuries.

Our culture is clearly Islamo-Judeo-Christian, and many words attest to that influence. Pretending that Islam is only the extremist Islam is a denial of history. Europe has a problem with Islam, which makes it crucial to work on learning history. In Bègles where I am mayor, I started an initiative, 'Faces of France'. Jews, Christians, Muslims...the idea is to show, through cultural workshops and music, that we are a summary/ synthesis of cultures and that it is going to continue like that. .

What form should the relationship between religion and the state take? How much room should we leave for religion?

The state is the guardian of freedom of creed, but must also demand mutual respect amongst religions. The public and private spheres must remain strictly separate. This is the essence of the French form of secularism as enshrined in the law of 1905. It was not easy to get through the hard head of the 'super-Catholics' and the church that they should go back to their place of origin. It is a major accomplishment and something that should be considered an entitlement, the result of fervent effort. Nonetheless, no one has placed a ban on a religion's right to express its opinion on societal subjects. For example, I voted against the law on the burqa, because I felt it was a notion of secularism that went beyond the state and entered into the realm of society. A woman should be able to wear a burqa if she would so chose. How could one know if she is doing it of her own will or out of obligation? Take the case before the European Court of Human Rights and you will lose every time. As Jean Baubérot – one of the foremost experts in the area of secularism – asserted, secularism has slipped from the state and entered society.

What place should religion have in public debate?

It should not play a role in public debate. Religion, generally, should be taught in school and that is lacking. That is where we can start if we want to avoid that dubious politician's use the subject for their own cause. I think that it is crucial to teach kids about all religions in a factual manner, if for nothing else, than to be sure that everyone understands each other's religion. Knowledge is the best weapon against obscurantism. If you keep people in ignorance, they will cede to obscurantism.

For example, Nicolas Sarkozy, while President of the Republic –

at the time he wanted to make history an elective subject in schools – he stooped so low as to say that Islam was the religion of those “who come from outside”. Yet there has been a mosque in Paris since 1923 and 95% of Muslims in the country have been here for 60 years. That is a way to persuade gullible and misinformed people.

How can political parties respond to the renewal of religious belief?

As a general rule, political parties have no role to play; they should not even be involved. There are several political parties that were founded on religion: the Christian Democratic parties for example. I find it unjust that people should be shocked if a party inspired by Islam were to be formed. No one seemed to be bothered by the fact that Italy was run for 50 years by the Italian Christian Democratic Right. Political parties can be attentive to religion but they shouldn't integrate religion into their platforms.

So, are you saying that the role of political parties shouldn't be one of raising religious issues, but of managing societal problems that relate to religion?

Religion shoved its way into French society, in particular via Islam. We cannot avoid the need to directly assess the role that religion plays and the problems thereby raised. For the extreme right the Muslims are the Jews of yesterday; they are pointed at as scape-goats. This has become a veritable subject of political debate. The role of people like me is to fight those that are trying to manipulate a religion in a way that is dangerous for society. That is what we refer to as essentialism, i.e., consider someone by virtue of the religion they practise and not for whom they are. This is currently one of the core issues.

Compared with other political parties, does political ecology differ in its stance vis-à-vis religion? Should it even have a stance on the subject?

No, political ecology should maintain a critical view of religions and keep its distance. The movement should not determine its stance based on religions, even if they are a part of our environment. Political ecology should observe and interact with religions, but it should also keep its distance because history has taught us that this is better.

In Europe, we have other examples of countries which seem more at peace when it comes to religion. The President of Germany, Joachim Gauck (elected in 2012), is a Lutheran pastor for example. The co-chair of the Green group in the Bundestag, Katrin Göring-Eckardt, headed the Synod of German Protestant Churches.

I am not sure if other societies are more at peace with religion, especially when I observe what is happening around me. It would be hard to say that is the case in the Middle East, maybe in African animist societies. The President of the United States of America takes his oath by swearing on the Bible. God help us if that were to be the case in France!

As for Germany, I am not surprised. The role of Protestantism in Germany is very different from the role of Catholicism in France. These societies are more influenced, as we can see through Max Weber's analysis. Stéphane Lavignotte, a Parisian Green activist, is a pastor. You can be a priest, an imam and still be a Green. That is not the problem.

Along the same lines, it has been said that inter-religious dialogue is better in the Netherlands than in France. That, however, has more to do with Protestantism making inroads on many societal issues. It has nothing to do with the size of France, but more to do with colonisation and the role that we played during that period of history. . There are many immigrants to the Netherlands and colonization did not happen in the same way as in France. Compared to the United Kingdom, for example, France has never been able to fully cut the umbilical cord.

•



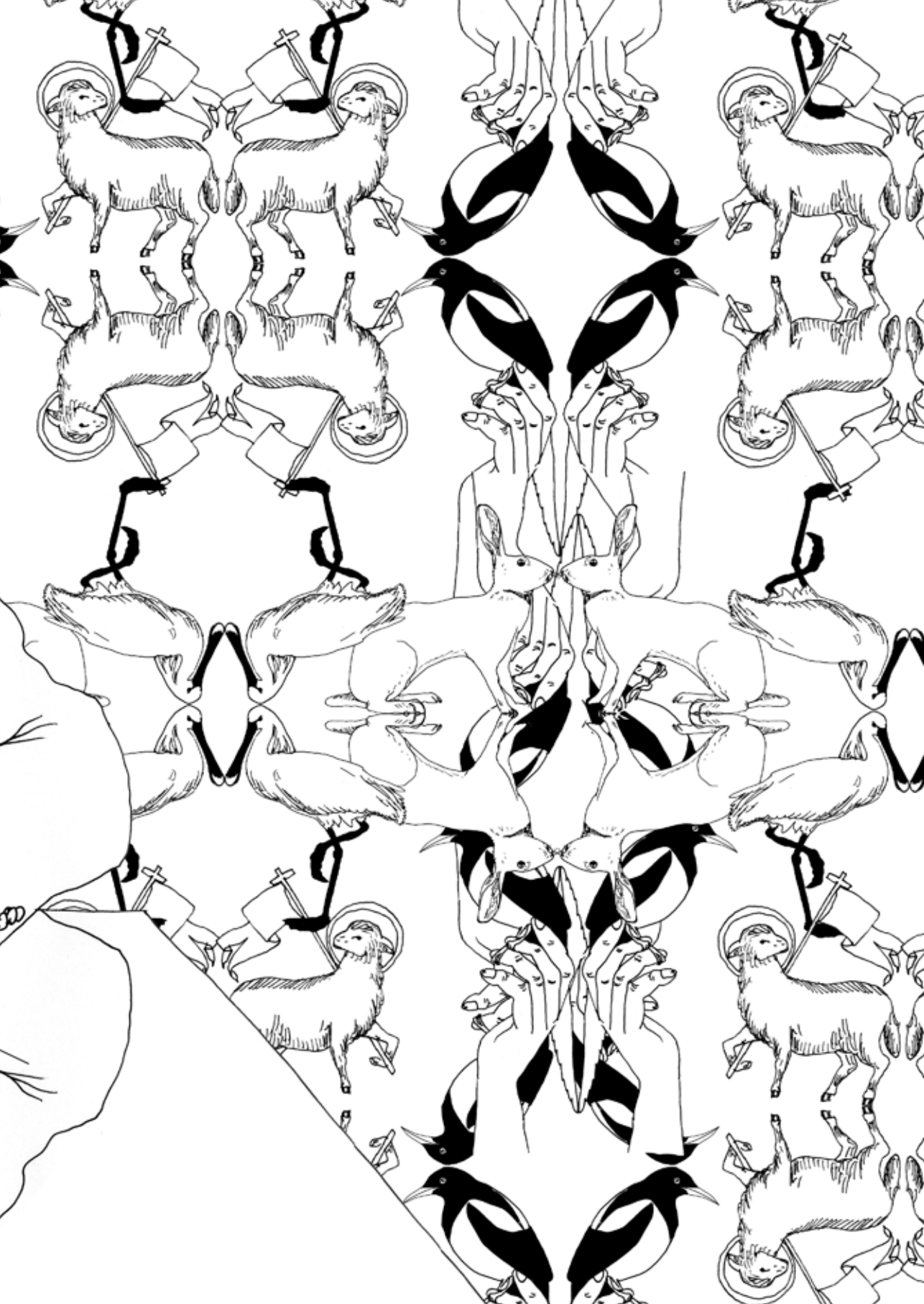

François Mandil:

If you are a Christian, you simply have to be an ecological activist



François Mandil (born 1983) is currently a national leader in the General Directorate of the Scouts and Guides of France (a Catholic youth movement), after previously working as a history and geography teacher. From 2008 to 2014, he was a Municipal Councillor for the Municipality of Pontarlier, which is in the Jura Mountains of eastern France. He was a member of the crop destruction campaigners known as the *faucheurs volontaires* (volunteer reapers). He campaigned against GM crops and was sentenced for reaping activity and for submitting a DNA sample. He was editor for the Lenten Campaign 2015 for Ecological Conversion.

If you are young, Catholic and your name is François (French for 'Francis'), people tend to think that there is a strong link to religion. Is there?

My parents clearly named me, at least in part, for Saint Francis. My mother comes from a traditional Catholic family, although she distanced herself from them somewhat. My father is a non-practicing Jew from Turkey. To me, this is an illustration of how lucky I am to come from a background that is rich in terms of history and culture, but which has questioned these pieties and has re-evaluated their beliefs. My name is François, and there is a link to Saint Francis of Assisi and I was cradled as a child by my patron-saint as I was a Wolf Cub (the name given to Scouts of age 7-11) and he was the patron saint of wolf cubs. He was the one who knew how to listen to animals; he spoke to the wolf, listened to the

birds and made an appeal for profound simplicity. So, in answer to the first question, yes, religion did play a role in my early life.

Could you tell us about the role that religion played in your youth and in your career path?

I had a pretty traditional upbringing with religion. I went to Sunday School and then, in middle school, I began to question. I went back to the source, to the texts. Traditionalists are not too keen on this. They prefer people to read what has been written about the Bible rather than to actually read the Bible itself. I read the Sermon on the Mount (Matthew 5-7) – the Beatitudes; ‘Blessed are the poor ... Blessed are those who hunger and thirst for righteousness’; and texts such as ‘You cannot serve both God and money’. Most importantly, I made the connection between belief and action in politics and religion. Political discourse is one thing but, if you do not actually practice what Christ preached, then why be Christian? I want to be entire in my approach – that might seem fundamentalist, but I want to go all the way.

The real question is transcendental: Does God exist? We cannot know for sure. I am equally as irked by people who categorically state that God exists as I am by those who say that God does not exist. The fundamental doubt remains. Yet, I feel that I have had a transcendental experience and have experienced something that I cannot entirely describe as I am not a theologian. It happened during events that I attended with the Youth Eucharistic Movement, always while in nature. I’ve always found Christ more easily in nature than in churches. Traditionalists are critical of this, but Christ can be found outside of churches as well as inside. The Sermon of the Mount is one example but, if we delve more deeply into things, I have realised recently that the questioning of the existence of God via the reasoning ‘if God exists then why would there be war, injustice, and tar sands?’ is faulty. You must take it on trust: God created the Earth for mankind and now mankind must figure it out; full freedom, full trust. Recently I realised that this thought was deeply linked to my environmental activism, to trust in individuals and freedom. The idea of ‘who am I to judge?’ is central. I think that one of the fundamental differences between the ecological dimension and other leftist paradigms is the idea of the individual, the strength of factoring in each person in a community; the somewhat anarchical idea that the individual

should be respected along with their choices. If you don't feel like going to the slaughter that is war like everybody else, then just don't go!

Let's take the question of abortion, for example. Pope Francis in Encyclical *Laudato Si'* reiterates 'everything is interrelated; life shall be respected from one end to the other'. There is a comprehensive message, which is important to maintain, and then there is the reality on the ground. Obviously, the right to abortion is a fundamental right that must be defended. It is needed because we don't live in an absolute world, where all is simple and binary and therefore this right has its importance. Defending it and saying it is important that women have the right to make decisions about their body, that no one else has the right to make those decisions for them, does not mean that abortion is cool, that it is a choice that is lightly made. Defending the right to abortion, free of cost, with free access, and free from judgement, is crucial, because it is this acceptance of the individual and the trust that we can have in each individual. Similarly, if we expand that thinking process, we can see that freedom of choice runs counter to an environmental dictatorship. At times, people state that it will be necessary to have an environmental dictatorship because we are just letting people do as they please. That's wrong. What we need is to have faith that each individual is grown-up and intelligent enough to figure it out. The human race will disappear sometime, that is not such a catastrophe, and anyway it is foreseen.

Take your environmental activism, for example, your actions with the GM volunteer reapers. Did you immediately make the connection between your actions and religion or did the realisation of that connection come after the fact? Or was there no connection?

GM volunteer reapers is just something that came about. It is a concrete manifestation of my activism. I thought there was something urgent that was required and that I had to go the whole way. I believe that the Gospels urge us to be active, to prepare the Kingdom in the name of Christ who is no longer on this Earth but who asks us to act. We cannot forsake the weak and the meek, or leave injustice to flourish. Therefore, we must prepare the Kingdom from here below. Yes, we must be active, we must go, and we must have mercy and be thirsty for justice. There are fifty thousand ways

to act. In my family, I was the only one who took the campaigning route. I think it was something of a coincidence that I entered politics.

What I appreciated with the volunteer reapers was that there was a community of elected officials who joined together along with the farmers' unions, etc. Food really comes down to a question of freedom – the freedom of each individual to choose. I am not going to defend the reapers here. What I liked about them was that there were really a lot of people and, as someone from the Catholic activism realm, I particularly and personally liked that they were everywhere. I went to the Anti-Globalisation Summit in Annemasse in 2003 when there was a G8 Summit in Evian. I had a chance to meet with the Catholic Committee against Hunger and for Development (CCFD) and Secours Catholique, and I realised that the majority of organisations from the South had a strong sense of spirituality and that liberation theology was far from dead. This encounter helped me and comforted me; sometimes we do not really see Christians, or we see them only when it comes to subjects that have nothing to do with our kind of activism.

There is no need to be a Christian to be an environmentalist; however it makes sense to me that, if you are a Christian, you simply have to be an ecological activist. To me this is fundamentally a question of coherence. It is good to see that there are other Christians who are thinking coherently and who say: “I feel strongly about this cause and I have become an ecological activist through my faith”.

In your view, what are the predominant challenges that European societies face in their relationship with religion?

To take the case of France – the case I know best – the real challenge is secularism. Secularism is used a bit in all of its iterations currently. Each side states that it is standing up for secularism and then quotes Aristide Briand (the French Prime Minister who was a co-laureate of the 1926 Nobel Peace Prize) to show that he is on their side. Yet, the 1905 law on the separation of the churches and the state – a great law incidentally – was designed to cordon off the Catholic church, and today the situation is very different. The major challenge in France in the area of religion, is how to separate public and private. I do not believe that religion should be something only for the private realm. If someone wants

to wear a burqa or a headscarf in the street, they should be able to do so. The public realm should be neutral and should not have an opinion on the subject. That is fundamental. At the same time, the right to blasphemy, to make fun of religion, like we make fun of anything and everything, is a right that should be vehemently defended. Cartoons can be very good and some can be very bad, but they must be able to be.

Could you perhaps expand on your view of the place that religion should have in the public realm and in the public debate?

Everyone has their place in public debate; everyone should be able to express their opinion and speak. Religions, as a general rule, in all of their different nuances, are organisations of a particular cultural and sociological import. So it is, of course, of great use for religions to be part of the discussion. They have a right to express their opinion. Similarly, people have the right to say what they think, and people also have the right not to listen and to say that they think that the message of the religion is ridiculous. I fully understand that there are a lot of people who believe that. And the right to be able to speak one's mind is a fundamental right, as is the right to state that another opinion is ludicrous. After all, organised religions are organisations of a human construct like any other. Again, we cannot say: "they may speak when it is convenient to me for them to speak". Atheist environmentalists are quite pleased with *Laudato Si* and that it carries such a strong message. Especially considering the climate emergency, we cannot sift through and pick out the good environmentalists and leave out the bad. They have a right to say that, on other subjects, the Pope speaks nonsense and they will, doubtless, be right. If he has the right to speak on environmental issues, he has the right to speak about other issues. When it comes to migration and social rights, environmentalists do not have much to say about what the Pope said.

What about the rise of Islam in Europe? Will it challenge the place of religion in European societies?

It transforms and shakes it up, but it will not challenge the place for religion in society. Islam lacks the highly organised structure that the Catholic or Protestant churches have, for example. Let's take the example of the Scouts. Muslim Scouts in France are Sufis.

So, many Muslim families prefer to leave their children in French Catholic Scouts than to put them in the Sufi Scouts. They figure that at least in the Catholic Scouts their children do not run the risk of being converted to Sufism. Therein lies the difference – no matter what – there is a moral authority in Catholicism. There are a tonne of jerks in the Catholic world who promote hate and who are despicable, but at least there is a Pope who has moral authority and who will speak out. That is what the word of Catholicism is. I do not believe that Islam constitutes a challenge to society – the more diversity, the richer we are and the more we realise how important that diversity is. How fortunate that currently, if I want to be able to discuss, exchange, and expand my thought process with Muslims, I do not have to travel thousands of miles. I have easier access to expanding my horizons.

Coming back to the political question, when it comes to political parties and their role in religion, is there a specific approach that should be adopted in terms of the place of religion in society?

I think much could be done in building an approach that focuses on living together. In this way the question of religion is involved, at least in part. Questions of living together come to a head where religion is involved. But the real issue is high levels of unemployment in less-privileged areas, the control of anti-social behaviour, and racism. It all revolves around a strong cultural and identity dimension that is religion. What could political parties have to say about religion, aside from denouncing the use of religion as an instrument in social questions? I do not believe that political parties have anything to say about the internal organisation of religion.

How will political parties be able to address the issue of living together and the conflicts that emerge around religious questions or, rather, conflicts that are born out of a contact with this religious realm? After all, that is a political issue.

Yes, issues of religion shake up our ability to live together because issues of identity revolve around that. That is because of US policy in the Middle East and the Near East, because of the Israeli-Palestinian situations, which are not really issues of religion in the strictest sense of the term, but are issues of land claims, racism and access to water. I think that political parties should couch it in

those terms. Political parties will do as they choose, but I believe this or that and luckily that is what my political party thinks. Once we have resolved the situation between Palestine and Israel, and there will be two states that will live in peace, then religious issues will be tempered in France because religions are used by some to wreak havoc by installing an identity response. It is a reflex to close off one's identity and that is really serious. At the same time, there is anti-Muslim racism in France, which is exacerbated by social, employment, unemployment, access to higher education and stigmatisation.

Do you believe that ecological parties are influenced differently by religion? Should they take a special stand in relation to religion?

It is important to point out that there is no need to be religious in order to be an ecological activist. Having said that, I believe that the question of transcendence means that you may have a different relationship to the environment. Therefore it is true that members of Green Parties may have a different perspective on spiritual issues because they have reflected on this issue. In France the big political parties are the result of an old culture that has not integrated well in a number of sectors. These are very interesting issues but ones where I do not feel I have enough expertise.

There are new areas of convergence between religious movements and environmental movements. Could you give an overview of the main values that you feel make these convergences possible?

In my mind, the nexus is respect for life, in the broadest sense, of the value of humanity and of each individual, and the feeling that we are a part of something that is bigger than us. There is a relationship to the long term that is very different and also to the all-encompassing nature of our environment. I do not have a plan for the human race. I have an all-encompassing plan that places people in their environment. I believe therein lies the nexus.

One last question – could you give us your personal definition of religion?

Religion is an attempt to collectively find an individual spiritual path. I am not sure if it is really clear, each individual has his or her individual spiritual path. Some feel very comfortable with this all alone and they achieve it individually. I am not that strong. I

was born into a Catholic country and a Catholic family, so I am a Catholic. Had I been born in Japan, I'd be Shinto, or in the Middle-East, I'd be Muslim. What really counts is to give each person the ability to follow their own path and at the same time to be on that path with others. I need to talk to people who have the same cultural references as me because that helps me reflect. I also need to meet with people who have very different cultural references. Religion is a way to collectively allow each individual to make progress on their own path.

-

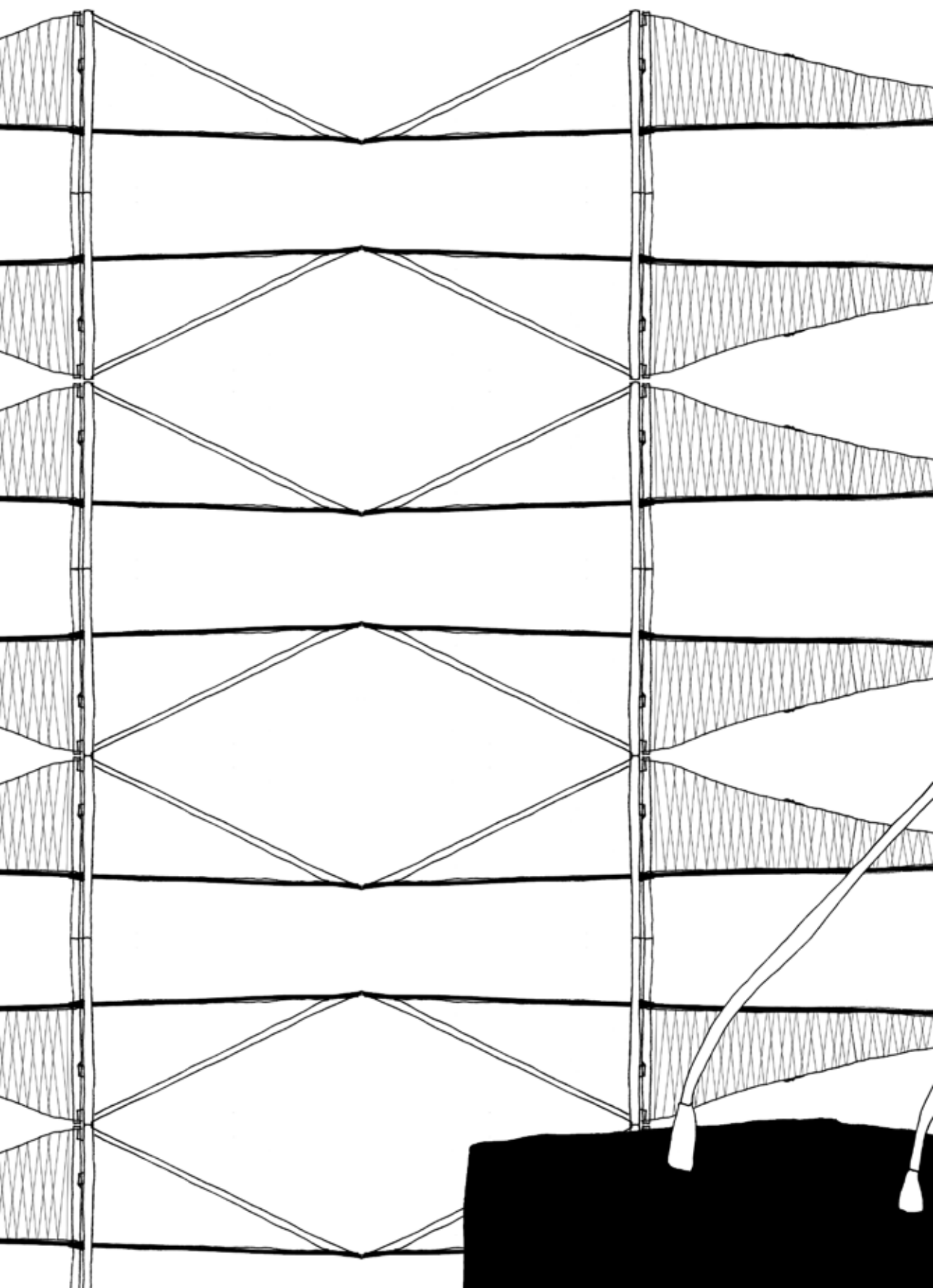



Meyrem Almaci:

When will you finally cross that bridge?

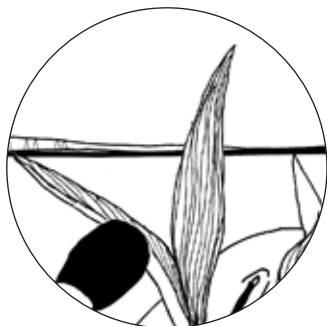

Meyrem Almaci (born 1976) is since 2014 president of Groen, the Green Party of Flanders. She is also a member of the federal parliament of Belgium, for which she gathered a lot of preferential votes. Almaci studied comparative culture and social work. She was spokesperson and president of Jong Groen, the youth organisation of her party. Until 2015 she was the leader of the Green Group in the Council of Antwerp. In parliament she specializes in financial questions and public budget.

Punctually, Meyrem Almaci arrives at the agreed point in Antwerp and gets off her bike, panting. It's warm and it's Ramadan. She tries to take part in things as much as she can, but with her busy diary that's a daunting task. "Ramadan is quite a strain on your body and that's why you may only join if you're physically fit. But Ramadan is about so much more than just yourself. It's a month of moderation, introspection and getting together with family, the neighbourhood and friends, and it's rounded off with a gesture towards people outside of your own circle, those worse off than you. Eventually, the underlying moral principles of solidarity and reconciliation give meaning to the ritual and the custom."

Does your religion influence your practical politics?

To me the principles I was raised with at home are moral lines of action. I grew up with sayings like 'Gören görünün hakkı var' (the eye that sees has rights too). In other words: eating and drinking

in the presence of those who are needy means you share, because some things are just luck, for example that you were born here. It obliges you to connect with people on the other side of the world, and with those who are worse off. The values I learnt at home – solidarity, self-respect, respect for others, integrity, taking care of yourself and your everyday surroundings – fit in well with the ecological body of thought which, for me, comes down to three related values: solidarity, justice and respect for the strength of people and the strength of our planet.

My father came to Belgium in the 1960s, my mother followed in 1974 with the family. With seven brothers and sisters, I am the second child that was born in Belgium. Two others died when my parents still lived in Turkey. My parents are Sunnis and traditionally religious. When we were young we went to Quran class and to Turkish lessons. Until the age of 16, I wore a hijab. Then I decided to stop wearing it on the basis of my own interpretation of the Turkish translation of the Quran. As far as I'm concerned, originally the hijab was worn in order for women not to be conspicuous. But if you apply that to today's society, you actually attract attention wearing one. It is not something ordered explicitly in the Quran. My parents reacted as true believers, not proceeding from tradition, but from the Scripture, which says that you cannot force people. "If I force you to wear a hijab then I bring a sin upon myself, even if I find it terrible for you to have to miss heaven, because I love you and want you to go to heaven with us" – because that's how they saw it – "but if I forced you to wear one no matter what, I would go against the spirit of what I believe in". I was the first girl not to wear a hijab in the small Turkish community in the little village where we lived. My parents were called to account.

How do you define religion?

I prefer the term 'outlook on life'. Religion is mostly associated with the faiths of the Book and, to my mind, that's too much of a restriction. I'm more concerned with a system of finding meaningfulness, with certain moral principles, traditions and rituals. This would include atheists, who derive their moral framework from the Enlightenment, for example. People experience religion in very many ways. Following the Enlightenment there was a struggle between secularism and religion in Western Europe which, after

the Second World War, led to a split between the local priest and the mayor. Fine, but that struggle should not result in a feeling of being uprooted. Many will say: we have liberated ourselves from the control of that one religion; we are not going to do that struggle again. But for others, surely for migrants, it's about everyday practice, not about a phenomenon of the past. There is that difference in history and evolution. Then there are converts who rediscover religion – take evangelical groups, for instance. So religion is very much alive. In a hybrid society we have to come to terms with these things.

Beginning with the recognition that people need to give meaning, which can be achieved in very many different ways, we need a basic set of inalienable values. Because whose truth is the only truth? As a government, there is only one option: guarding the freedom of people's outlook on life, from atheism to the religions of the Book and everything in between, starting with hesitation and not with whether one specific group is in the right. People in the Public Service who have to make moral judgements on the lives of others must be non-partisan because at that moment they represent and symbolise the government.

The school is a place where public and private come together. What is your view on religious symbols in education?

Personally I have no problems with them, but I can imagine that others have a hard time when their children's teacher has a totally different outlook on life than the parents. What I do find unacceptable, however, is denying your pupils the right of expressing their outlook on life, as is the case with the Antwerp ban on wearing the hijab in the classroom. Then the right to education is liable to suffer. As a feminist I wonder: who is the victim and who do you help? Many people think: we had better take away those hijabs from those girls' heads – historically, however, forced emancipation has never worked anywhere in the world. It's counterproductive.

The small group which is really pressurised vanishes (because those girls stop going to school) and actually you force them deeper and deeper into difficulty. And to the girls who are self-consciously shaping their identity you're saying: because we interpret the hijab in this way, you don't have the right to turn it into another symbol.

We decide what it stands for. But you aren't even Islamic! What gives you the right to interpret religion in this way and subsequently put that interpretation above the perception these women hold? That's not democracy. That's a society based on the fears and projections of one specific, dominant group. That's not the kind of society I believe in.

You didn't oppose the banning of the burqa. What's the difference?

I abstained. I had severe doubts about the ban, because how do you know whether a woman is wearing the burqa out of her own free will or whether she's forced to do so? A lot of research shows that most women choose to wear it. But even if the burqa is repressive, then a ban would be a totally wrong approach in addressing it. In the meantime, subsidies are scrapped for initiatives that support women suffering from domestic violence. Apparently we want to fight the symptoms, rather than making money available to address the underlying problems, such as that one in four women in our society 'fall down the stairs': let's for once stop putting everything in a cultural context. I put on a burqa once just to feel what it means. It's a cocoon, which some might feel comfortable in, but it frightened me, closing yourself off from society. It means the total failure of what I believe in, namely integration instead of segregation. Everyone has the right to dress the way he or she wants to, but it hampers the dialogue between people enormously. By abstaining, I just wanted to make clear that it seriously worries me.

This debate in the Green movement isn't closed yet. At the European Green Party's Council Meeting in Zagreb in May 2015, a debate started about the hijab, in which some said: we must liberate Muslim women.

I find that paternalistic. You don't have the right to decide for other women how they should address their struggle for liberation, because it differs in every context. Migrant women don't opt for the western way automatically; they use their own symbols and ways. That includes sexual liberation: who am I to demand from LGBTs to come out of the closet if it works for them in a different way? I may regret it, but eventually it's their choice. There is a difference in cultural strategies: you may react against some things and you make use of other things to change things within the community. Women in the Middle East remove their hijabs as a way of protest, while here it is used as a statement of one's rights. It's a different

context; it's a different strategy, but not necessarily less sound.

Such a reaction tells me in particular that we need a lot more bridge builders and we must get into contact much more with feminists in other communities. It's a question of 'don't know, don't want to know'. It's not a matter of unwillingness.

I grew up in the hub of diversity, both at home and at school. Some of my sisters wear a hijab, some don't. I went to all kinds of schools, from deeply Roman Catholic to notoriously liberal. It started as early as the Roman Catholic kindergarten. On Ash Wednesday we received the ashes. When we got home at noon my mother would wipe them off, but when we went back to school she put them on again. It was confusing for me as a child, but all those experiences have turned me – sometimes reluctantly, but very consciously – into the bridge builder I have become.

But now the time is over for me to be the one who has to commute between the various groups. I'm starting to have had enough of that. I see that fatigue in bridge builders everywhere. The bridge is already there: will you cross it for once?

Aren't those bridges blown up by terrorist attacks and radicalisation on the one hand and the reactions to them on the other?

Absolutely. Worldwide we have been shunting our responsibilities for decades and that's hitting us hard in the face. But that's not so much a story about religion than one about the Internet, immigration, trade and economic interests. Religion is used to legitimise war, repression and violence. But eventually it's all about acquiring power and money.

So religion is two-faced? It can inspire good things, but legitimise a lot of misery as well?

Yes. There are people who do wonderful things on a small scale. There are those who, starting from their religion and outlook on life, do marvellous things on a small scale, but you see that religion has catastrophic consequences if it's used to justify violence or even barbarism. You can't dismiss this saying: this isn't true Islam. From the moment someone starts using religion to legitimise gruesome things, for example, ISIS, then you have to resist it. I am not responsible for ISIS' beheadings but I'm affected by them just as painfully as you are. What's more, ISIS doesn't differentiate between Muslims and others. So can we now develop a strategy together? It would be

a big mistake to think that we are able to solve this by withdrawing into our group; the only possible answer is humanitarianism. And in the case of ISIS, repression as well. Ecologists are pacifists, but with regard to this kind of horror you do need a multidisciplinary strategy, including repression.

But let's be honest: with Bush's attack on Iraq, a fuse was lit which we've never managed to extinguish. Finally we are forced to think about all the things we are doing in the region and how we can become part of the solution. The people there are having to live under ISIS and Assad, between hammer and anvil so to speak. I think I would take to the Mediterranean in a dinghy.

The right wing reaction to this situation is to come up with the image that European civilisation is diametrically opposed to Islam.

That Europe has Jewish-Christian roots is fiction. The Ottoman Empire once stood before the gates of Vienna. Look at Spanish architecture, and all those old paintings of western rulers in a sultan's outfit. Ottoman civilisation was idolised. Of course, there has always been a tense relationship. Look at the crusades, but Islam has always been here. The idea that Islam is new in Europe is the same kind of nonsense as the claim that Islam hasn't experienced the Enlightenment and still has to. Islam is multifaceted. Research has shown that the great majority of Muslims cherish the principles of the Enlightenment.

I do not believe in history as a rising curve; as if after the Enlightenment everything was in order in Europe. Europe went down steeply again when it was over; just think of the Second World War and the war in Bosnia.

The Enlightenment has had great significance. The separation between the branches of government and the separation between church and state was an incredibly important feat. You will never hear me downplay its significance, but it's not as if it's an everlasting achievement. Something that 'they' don't have and 'we' do. On the contrary, you can see a number of principles from the Enlightenment coming under pressure, like the freedom of religion and a number of basic democratic rights, such as the protection of our privacy. Under threat, all kinds of issues that are important for a democracy perish while we must uphold them here and elsewhere.

Fundamental democratic rights tend to clash. What was the viewpoint

of the Greens on a ban on ritual slaughter?

We are in favour of stunned slaughter but we want it to be introduced by mutual agreement with the communities concerned. The debate has not been conducted properly. Non-stunned slaughter is always put on the agenda during the Islamic Feast of the Sacrifice, but Muslims, Jews and some animist religious communities do it all year round. I myself became a vegetarian when I was sixteen, because of my love for animals and disgust with the meat industry but also because of my religion at home. My father went to a farmer himself to pick the strongest lambs. They would stay at the farm for another two years. When one of them was slaughtered there'd be a prayer for the animal's soul, and the killing happened with a really sharp knife, as brief and painlessly as possible. The whole family would be present and every time we'd say: it's difficult. If you can't deal with the fact that you're taking a life, stop eating it. But where do you get lessons in life like these today, in the way we eat meat?

Let's deal with the debate on stunned slaughter in its totality, outside of the religious celebrations. Because now many Muslims have the feeling that it's all about ruining their celebration. Animal welfare groups make you understand why they draw attention to this issue during the Feast of the Sacrifice, but as a government you have the duty to keep the public interest in mind. There are numerous religious Islamic countries where stunned slaughter takes place. Go and have a look there and see what the possibilities are. When you polarise the debate, you get a cramped fist instead of an open hand; no-one will leave the trenches. I regret enormously that religion and animal welfare have become so diametrically opposed, because in religion too, and definitely in Islam, there are enough starting points to ask questions like: is the way in which we eat meat still in line with the rules? And then it's not only about those last few minutes. An animal must be healthy, old enough, mustn't see the knife and must be free of stress. In most slaughterhouses, both halal and non-halal, the procedures vary. Someone once said: If Mohamed lived now, he would be a vegetarian.

But you have to be firm and judge the production of foie gras, hunting and the bio-industry along the same animal welfare lines. Because when it comes to the traditions of the dominant group – the Christmas turkey or the typically Dutch Feast of Saint Nicholas – the reactions are exactly as emotional as those of Muslims when you point an accusing finger at their Feast of the Sacrifice. My

comparative literature studies taught me that making these kinds of comparisons help to take away an issue out of the confinement of culturalisation. In short, as the Green Party we are all for stunned slaughter, but we don't want to end up in a disguised Islamophobic debate.

Do you see religion as a source of inspiration or as an obstacle to Green politics?

Generally I think that everything that gives people meaning inspires, at least for me. Religion becomes an obstacle when people start attacking your religion when something negative happens on the other side of the world. Then people start flooding me with phone calls. As if one Flemish person has had to account for Dutroux' gruesome crimes or all Catholics having to account for sexual abuse by priests. What does that have to do with what you yourself stand for! Muslims suffer from the *guilty by association* mechanism. What it does to young people worries me. How does it affect you when time and time again you are pinned down, and always negatively, to the Islamic side of your identity? Don't be surprised if suddenly young people turn their backs on society as they can never do anything right because they're Muslims.

All political parties, including the Greens, should take this up: stop looking at only one aspect of people's identity. Identity is always layered, complex. It's like lasagne: it only tastes good if you take a bite of the whole thing. You cannot separate all those layers in an essentialist way and zoom in on one aspect. No-one's made up of just one layer.

Asking questions about diversity in society is asking the question about the balance of power, not only between the native population and immigrants, but also between groups of migrants themselves. And so in the end, it's about the socio-economic situation. The singularity of people's cultural and religious background is generally much narrower than is conceived. Minorities also worry about the bank crisis; they too want to know how we are going to create jobs and how we are going to make education work. And yes, they themselves do discriminate too. Political parties should not approach them as separate groups, but simply as voters.

•





Marco Schreuder & Tina Walzer: Recalling the heyday of Vienna's Jews



Tina Walzer (born 1969) is historian and author. She is specialised in the research of European Jewish Cemeteries and published in 2001 with Stephan Templ the book Unser Wien Arisierung 'auf Österreichisch' (Our Vienna, The Austrian way of Aryanization). In 2011 she wrote Der jüdische Friedhof Währing in Wien (the Jewish Cemetery Währing in Vienna). Walzer is co-editor of the Jewish cultural Magazine DAVID.

Marco Schreuder (born 1969) is since 2011 Member of Parliament for the Austrian Greens. Until 2010 he was active in Viennese politics, where he was the first openly homosexual member of the City Council. Born in the Netherlands he emigrated in 1975 with his parents to Austria. He studied History of Art at the University of Vienna and Theatre Direction at the Max Reinhardt Seminar. He was editor-in-chief for Bussi, a Magazine for homosexuals, and speaker on human rights and discrimination for the City of Vienna.

In the 19th district of Vienna, hidden behind grimy walls, lies a forgotten treasure: the Währinger cemetery, which was in use by the Jewish congregation from 1784 until 1884. The graves tell the story of the heyday of the Jewish community in Vienna, which today is hidden from view by stories of war and persecution. Marco Schreuder and Tina Walzer have been working together for ten years to make this place visible and accessible again.

What motivated you for this project?

Marco Schreuder: In 2006 I had just become a municipal councillor in Vienna and was especially known for being a gay activist. I wanted to broaden my outlook. When I read an article about the cemetery, I took interest immediately. I was born in the Dutch village of Putten, which in 1944 was raided by the German occupiers in retaliation for an assault by the resistance movement. The Germans deported the majority of the male workforce to the concentration camps. My parents raised me as a Jehovah's Witness. The Jehovah's Witnesses were persecuted by the Nazis too, as were homosexuals. As a result, the why and the how of the dynamics between perpetrators and victims has always fascinated me. The Währinger cemetery was closed in 1938, after Austria joined National Socialist Germany. In the Nazi era a lot was destroyed. Some graves were ransacked. The Jewish community of Vienna, many of whose founders found a resting-place at this graveyard, was destroyed. The story of these people needs to be told.

Tina Walzer: Part of my family is Jewish. I have always known that they died under the Nazis, and how, but I wanted to know more about their lives. The cemetery dates from the heyday of Viennese Jewry. For me, it is important to reconstruct this past in order to bring about a positive identity. You can't just identify with war, violence, suffering and death. That is not a way to lead your life. Values such as tolerance, understanding, listening to one another and accepting one another are important to me. The Währinger cemetery in particular is very much suited to conveying these values, because it dates back to a time when they were acted on. As Austrians, as citizens of Vienna and as members of the third generation after the Second World War, it is important for us to retrieve the Jewish past in our consciousness as part of the history of this country. I was very happy when Marco contacted me, although I laid down one condition, namely that the cemetery should not be used for party-political aims.

And how do you do that?

Marco Schreuder: Tina gives guided tours of the cemetery, and we organise special days for volunteers where people of all ages and a range of political and religious backgrounds help to clean up the cemetery and do all kinds of repair jobs – all organised and

financed by the Greens. We are clear about our involvement, but do not use the work we do for campaign aims. And all our activities are always communicated with the Jewish congregation.

Can you tell a bit more about the cemetery?

Tina Walzer: With its two hectares and over 8,000 graves, the cemetery is a mirror image of the Jewish population from the end of the 18th until the end of the 19th century. In that period the ideas of the Enlightenment were embraced and realised by the Viennese Jews. They integrated into society and became secularised. They played a decisive part in the industrial revolution, the world of art, the construction of modern society and the political system as we know it today. Jews and other minorities were given civil rights. Without that Jewish contribution, Vienna and Austria would have looked different today.

Marco Schreuder: Remarkably enough, my first association was with the old Egyptian graves. The way we learnt about ancient Egypt and Egyptians through their graves, I learnt about the Jewish community of Vienna through this cemetery. The dominant images in the Austrian consciousness about Jewish history are those of piles of bare, emaciated corpses in the concentration camps. These images are so predominant that you forget that these people once lived flourishing lives. Paradoxically enough, you can really feel this at this spot. It's a place of the dead, but not of horror. On the contrary. Here you really become aware of the enormous shock that the years 1933-1938 must have brought about, because you discover how liberal, open and strong the Jewish community was. Confidently people dedicated themselves to the construction and modernisation of society. How abruptly it came to an end strikes you even more strongly, as you don't meet the war generation, but their parents and grandparents.

Tina Walzer: For me it is a place of beauty and quiet. You can tell your visitors that meeting Jews can be a positive experience, unhampered by guilt and horror. You notice that too on the volunteers' days when afterwards people ask when they can come back. I don't know their personal motives to come and help, but then you see the faces, radiating light with fulfilment. The work does people good emotionally. Especially for the young, it's important to get to

know the history of the Viennese Jews from a positive perspective. In co-operation with schools, we invite young people from other religious communities to visit the cemetery. It is our experience that many Muslim youngsters have many prejudices with regard to Jews. After a visit to the cemetery they say: "I didn't know about this, it's been very interesting, now I can picture the Jewish history of my city".

That's of great significance. For me, the work with this cemetery is an integration project to a large extent. There is a threshold still, an anxiety to even pronounce the word 'Jew'. People sometimes ask me if they're indeed allowed to use it. Also I'm often asked to help people contact the Jewish congregation, because they're afraid to do something wrong and they don't know how to get in touch, who these people, these Jews, really are.

Has the co-operation with the Jewish congregation changed you, Marco?

Marco Schreuder: Over the years you get to know each other and start building confidence. When there was a discussion in the Jewish congregation about homophobia, they asked me for help. Also we organised joint campaigns against anti-Semitism. Within the Greens there are various views on anti-Semitism. I belong to the strict faction. There are the classical left wing anti-imperialists, who see Israel as the worst of the worst. They say: the Palestinians are oppressed and we must help them. There is also an anti-German group, which is pro-Israel and they say: what the Palestinians are doing is anti-Semitic and you have to act against it. Traditionally, the pro-Israel group tends to belong to the Greens while the pro-Palestinians tend to be social democrat. But within the Greens too, it's awkward. That's why some of the meetings against anti-Semitism are supported by me as a private parliamentarian, but not by the Party.

With regard to Israel, I don't believe that all criticism towards the state of Israel comes down to anti-Semitism, but if it gets one-sided... In parliament a resolution was tabled condemning Israel for detaining people without trial and arresting them without a court order. I think criticism like that is appropriate. However, I couldn't support the resolution because the Palestinians are doing exactly the same, as do many other countries by the way. So it's a one-sided proposition, consciously aimed against Israel and that's why I place it within an anti-Semitic context. My close

and long-standing contacts with the Jewish congregation have strengthened the views I already held.

Have your views on religion changed as well? With a background as a Jehovah's Witness, Judaism is a different kind of religion.

Marco Schreuder: Of course it's different, but every outlook on life is. I'm in favour of a pragmatic attitude: this is a city where many people have many different outlooks on life. I don't care who they marry, or how they want to live, as long as they do not restrict other people's freedom. By showing a rosary, by wearing a hijab, a turban or a yarmulke, or by waving a rainbow banner as I do, you can show your affiliation, your belief. Indeed, I think it's important to make diversity visible: everywhere problems arise by barring religions from public life. Look, for me I draw the line at indoctrination, where teachers for instance want to convince others, something that cannot be condoned. A child cannot choose its teacher, that distinguishes it from a political debate between equals in which you can convince one another. But I have no problem with police officers wearing a hijab, for instance.

With regard to education, I am all for the abolishment of traditional religious education, whereby each child receives instruction from a teacher of their own religious denomination. I would opt for lessons in ethics for all children, both religious and secular. In those lessons, rabbis, imams, and clergy could come and tell about their faith. I think it's important when Muslim children get to know the pastor, Jewish children get to know the imam, and atheist children get to know a Buddhist. All outlooks on life should be dealt with.

As for me, visibility is the key to emancipation. Look at the success of the gay movement. Who would have thought ten years ago that gay marriage would be legal everywhere in America? Even in Austria, 70 per cent is in favour of same-sex marriage. And what was the strategy? Being visible, visible, visible.

How do you view the tension between homosexuality and conservative religion? Many gays don't want to have anything to do with religion.

Marco Schreuder: I myself left the Jehovah's Witnesses for that reason, so I do understand. But I'd rather tell the story the other way round. My mother stayed inside her church. She had to learn to deal with a gay son, and I had to learn to deal with a Jehovah's

Witness as a mother. I could have broken up the relationship, but that's not a very nice thing to do. Eventually, you have to meet each other halfway, tell each other: "let's agree to disagree". Then you can see eye to eye and go for a walk together, or go to the opera.

As long as there is no violence, maybe it'll succeed in this way.

Marco Schreuder: Naturally, there always looms the question, even in the liberal state: where do you draw the line? As for me, the state has to exercise restraint when it comes to interfering in family life and determining which values parents ought to raise their children with. The state must offer help to youngsters who are in conflict with their orthodox or fundamentalist families because they came out of the closet as gay, for instance by supporting and promoting aid programmes in this field. But the dividing line is faint. A lot depends on how the debate is conducted. In the debate about circumcision it struck me for example that it was mostly white, uncircumcised men with a Christian background who wanted to make out a case for a ban on circumcision. I didn't hear any Jewish or Muslim men who were saying: we don't want this any longer, we are the victims.

I asked orthodox Jews: what would you do if your daughter was a lesbian or your son was gay? Often these are difficult conversations, but you have to have them. But I'm all against coercion. It leads to a kind of civil war we can do without.

Tina Walzer: Coercion always leads to resistance. If you play off two fundamental rights, you corner everything and everyone, and solve nothing. I, for one, see religions as important pillars of society. Whether you join something as an adult or not, religion is a fundamental cultural heritage and an indispensable building block for integration in society. People should take knowledge of the fundamental values of the great religions, and their histories. That's the only way to counter fundamentalism and bias. That's exactly what we're doing at the Währinger cemetery: raising awareness, informing people, organising meetings and encouraging people to engage in personal relationships. Because I believe that coming to terms with the past can only occur at an emotional level.

It would be great if politicians supported and facilitated this. But at the moment it's only the Greens doing so in Vienna.





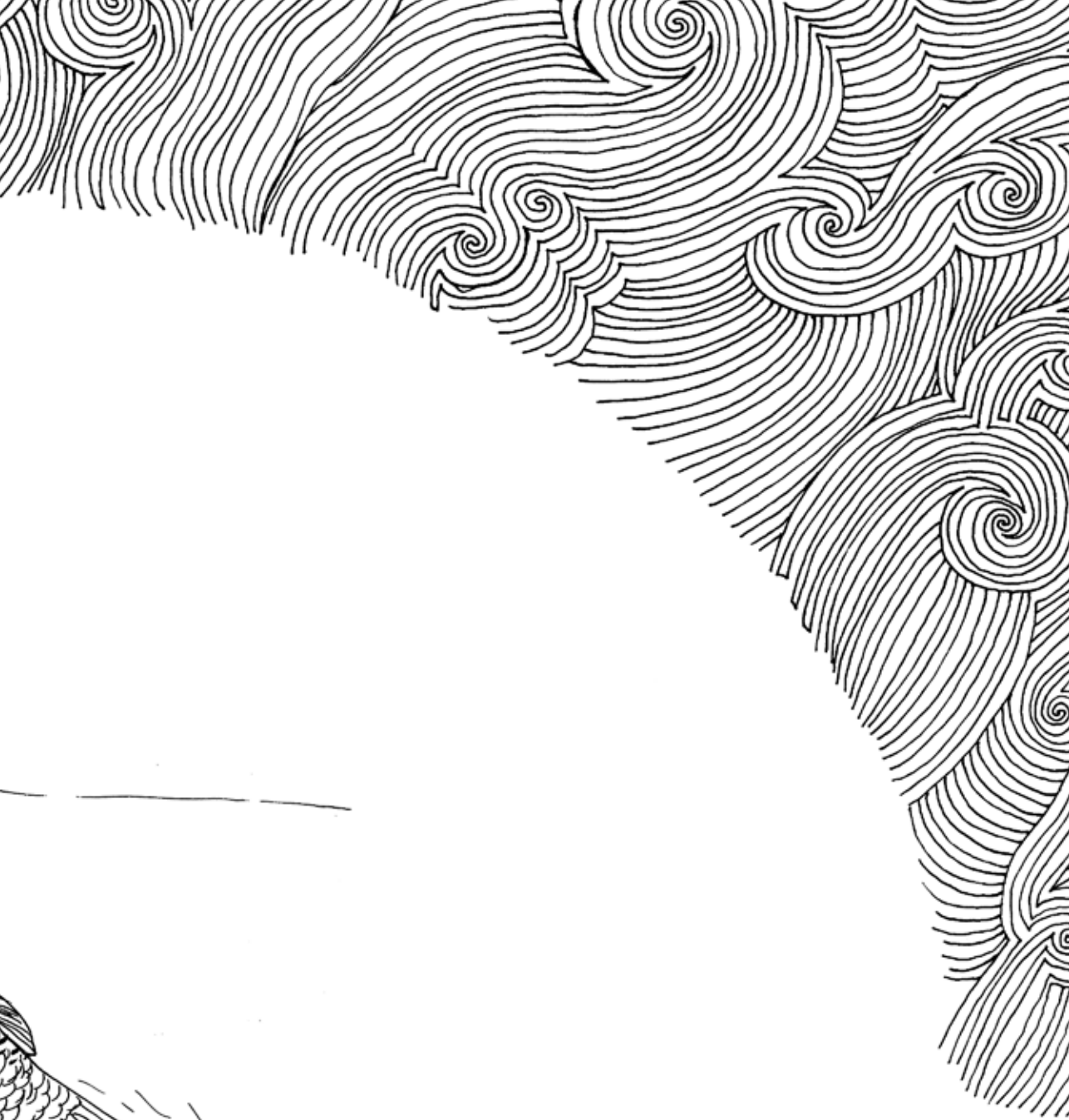

Adam Ostolski:

What is sacred for us may not be sacred to others

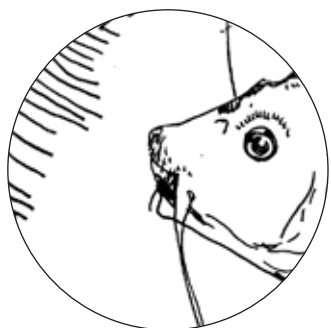

Adam Ostolski (born 1978) works in the Institute of Sociology at the University of Warsaw. He is the co-chair of the Green Party in Poland and a member of the board of the Magazine *Krytyka Polityczna*. He is editor of *Kościół, państwo i polityka płci* (*The Church, the State and Gender Politics*, Warsaw 2010) and *Gra o Europę* (*Game of Europe*, Warsaw 2013), and co-author of *Stimmen für Europa* (*Voices for Europe*, Göttingen 2015).

Can you tell us about your own religious background?

I was raised in a Roman Catholic family in a small town in Poland. Religion was part of our daily life. When I became older, I read about other religions and became interested in Buddhism. Actually, it started with animal rights. I thought they were not defended enough in Christianity. In Buddhism I found more respect for animals and nature, I also learned how important it is not to get attached to forms. There are a lot of forms and rituals in Christianity, and you need them, but they should always be flexible. That is what spirituality is about for me. For the same reason, I did not need to officially break with Catholicism. To me, Buddhism is a clearer continuation of what Catholicism meant to me. It is about being a compassionate community; Buddhism is a more practical way to practice mutual care and sharing.

Does this experience influence your attitude in politics?

Yes, definitely. In politics I am looking for the same kind of balance:

not to be too dogmatic, but not to be opportunistic either. It is important to understand in what way people are attached to forms to be able to transform them. And that is what politics is also about.

Against this background, how would you define religion?

I will give you two definitions that I think can be useful. Firstly, religion can be a creative force for a community that creates its identity through it, and also creates a political force in the process.

Secondly religion is a form of spirituality – a point of reference that allows us to look past the world we live in, the conditions of our lives and the social and political rules that bind us together.

This definition leads us to imagining a better, more just world. Such a world could be more conservative or radical. In both of these scenarios spirituality is a source of imagining other ideas about social interactions.

What are your experiences with the presence of religion in the Polish public sphere?

I think that the dominant understanding of religion in Poland is similar to the first definition. Religion looks more like an attribute of the national identity or a tribal symbol than something that makes us change our ways of life or the world. Such an understanding also gives us absolution from our past and present deeds.

I think that situations in which religion mobilises us to actively engage in politics are more interesting. That could be seen with the ideology of ‘the civilization of life’ and ‘the civilization of death’, promoted by John Paul II. It encouraged the opponents of women’s reproductive rights or sexual minorities – therefore was a conservative stance. We should look at it as an idea of a different world, built upon the idea of ‘sanctity of life’, that needs to be defended in a political and cultural fight. But that is not the only way of using religion in politics. The same topics are discussed differently in the documents created by Pope Francis. We can see no ‘clash of civilizations’ there. In *Laudato si*, when referring to abortion, instead of usual ‘unborn child’ he decided to use a neutral term ‘human embryo’, that creates much less pressure on enforcing Catholic worldview on the secular state laws. This stance looks more like social spirituality. Its main pillars include striving for social justice, caring for the poor, ethics of sharing with one another.

You think that ideas promoted by Pope Francis have no chance in Poland?

On the contrary, I think his attitude may influence not only leftist, Catholic intellectuals, but also people rooted in popular Catholicism. I remember that in spring 1989 I read in a newspaper that a group of MPs from the Communist Party drafted a law supposed to 'protect unborn children' and make abortion punishable by two years of jail. I was a religious child so I took the newspaper and went to my grandmother, saying: 'Grandma, we need to write down the names of these people and vote for them'. My grandmother, who was a deeply religious person all her life replied, 'we need to write them down... so that we will not vote them under any circumstances'. That was a shock! My grandmother told me a Catholic interpretation of supporting abortion rights.

She told me that if we pass such a law the levels of abortions will not drop, but women will suffer more. That was common sense – a perspective that differed both from the language of feminism and the narrative of 'defending life'. I think that such a view – full of empathy and detached from any ideology – has solid roots in the 'common-people Catholicism'.

Let us now discuss the current state of affairs in Poland, in which we can see tension between the churches and the state.

The biggest problem is with religion in the schools. When you look at opinion polls the majority wants such lessons. When we ask them more concretely we can see that most of their proponents want pupils to learn about many different religions and not to be preached. They want religious education that will prepare to live amongst people from different cultures. That sadly is not the reality in Polish schools. There is also another problem. People teaching religion in schools the priests and nuns, are subordinate both to the local bishop and the school-board. The latter is *de facto* fictional and the state authorities do not intervene even in cases of obvious abuse. The catechist is also a teacher – and therefore a member of the school-board. It is important as this body not only discusses issues related to educational progresses of pupils, but also their behavior and even their personal and family situation. This is not only a huge responsibility, but also huge power. In practice it is the religious institutions that control the public sphere of education. The influence of the Catholic Church on education is not limited

to religious education. It uses its influence on politicians to block attempts to introduce quality sexual education. These lessons are often taught by catechists after preparatory courses. The knowledge they pass on to pupils is often based on superstitions and not on science. Such an education strongly influences the situation of women and minorities. The Catholic Church in Poland thinks that the European convention, protecting women from violence is... anti-Catholic. Polish bishops are alarmed by the idea, proposed in this convention, that religion and tradition may be a source of violence against women. I consider such a statement as something quite obvious. Religion can be a source of inspiration for changing the world for the better, but also for domination and inequality.

From what you are saying it turns out that all of these debates focus on the Catholic Church and its position.

Well, I once got fined for defending the right to build a mosque in Warsaw (*laughs*). There was a demonstration of people who were against it, shouting slogans about ‘jihad’ and ‘the Islamisation of Europe’. I went to a counter-demo which did not have a permit so participants were fined. We will be having much more of such conflicts, especially if we open up to immigration. We will not avoid the issues related to coexistence of different cultures.

Are we prepared for that in Poland?

I don’t think so. In 2013 we had a discussion about ritual slaughter – killing animals with no anaesthetic for kosher/halal meat. Recent years have seen a rise of industrial ritual slaughter for export. Animal rights activists demanded a ban on such activities. Representatives of religious minorities emphasised their right to religious freedom, demanding the right to such slaughters for their own needs. Eventually a full ban was introduced.

It was a confrontation between religious regulations and the secular law of the state – but also between cultural practices of the minority and the majority. A ban on ritual animal slaughter was passed thanks to an alliance between animal rights activists and people wanting to show superiority of the Christian civilization over ‘barbarous’ minorities. At the same time 6 million live carps are sold each year before Christmas Eve. It is a brutal tradition that is much harder to eradicate.

The discussion about ritual slaughter showed that we are not

yet ready for serious debates. I had the impression that both sides were defending their own moral high grounds. If we want the society to function properly, we need to start living in a world of many values. We need to understand that something sacred for us may be not be sacred to others. This is difficult for me, as I started my social activism in the animal rights movement. But politics does not mean imposing our worldview on others. It means that people that differ from each other are still able to live together.

Can religion be a source of inspiration for ecopolitics, or are they more of an obstacle for making Green ideals come true?

They can be both. I know many Greens inspired to political activism by their Catholic, Protestant or Buddhist beliefs. Before Poland joined the European Union I made some research in one village. One of the questions was ‘Is there a person who is an authority for you and – if so – did they convince you about anything?’ One woman told me that John Paul II convinced her to forgive Ukrainians. A few years later I heard a sermon preached by a Catholic bishop on TV. The first one was about the need to reconcile with Ukrainians. The second was about the dangers that the ‘gay lobby’ presented to the Polish family. I think that such a connection is not a coincidence – the conflict has been shifted, but the need for an enemy remained. However I see a change for the better with the new pope. He reaches out to people from the lower social strata and forced bishops to listen to them. There are also subtle but important changes in the way sexual ethics or women’s rights are being discussed. The stances of the Church remain the same, but they are not presented in the rhetoric of ‘the clash of civilizations’. It is not a ‘cold war’ with the world any more.

The most interesting part from the ecopolitical point of view is *Laudato si*. We can see there a very Green view of the ecological crisis. We know that there are no magical solutions and there are different ways of getting out of it – technocratic, conservative, lifestyle-based or neo-liberal. Greens strongly combine ecology with social justice, the critique of corporate rule and the global inequalities between North and South and social activism. It is striking to see a similar point of view in the papal document. We also find an interesting idea of change of our ways of life. It is a huge challenge. We know we need to change to live within planetary

limits. We also know that individual change is not enough and it would lead to de-politicising ecology and blurring power relations. That is where ecology meets spirituality. In *Laudato si* ecology and social justice combine not only with the critique of global capitalism and the call for change in production and consumption patterns. A new vision of culture emerges in which care for the people and nature is more important than right now. It is a vision that can be considered spiritual.

I think political ecology needs spirituality – not necessarily represented by one religion. It can be an answer to the need for change in our individual lives. We cannot force it by law, as it would be considered oppression. Focusing just on economic incentives is also not the way forward as they influence the lives of the poor who do not significantly contribute to the ecological crisis, but are useless for the rich. In order to change their ways people need to take care for the world in which they live. Spirituality kicks in when we see that money and power alone will not solve all of our problems.

And what do you think ecopolitics has to offer religious people, engaged in their churches?

If religion has a spiritual level, than it means that along with it comes a call to transform our ways of life, our relationship with the world and the world itself. I believe that Green politics – due to the values it proposes – is the best place to make spirituality influence politics.

•



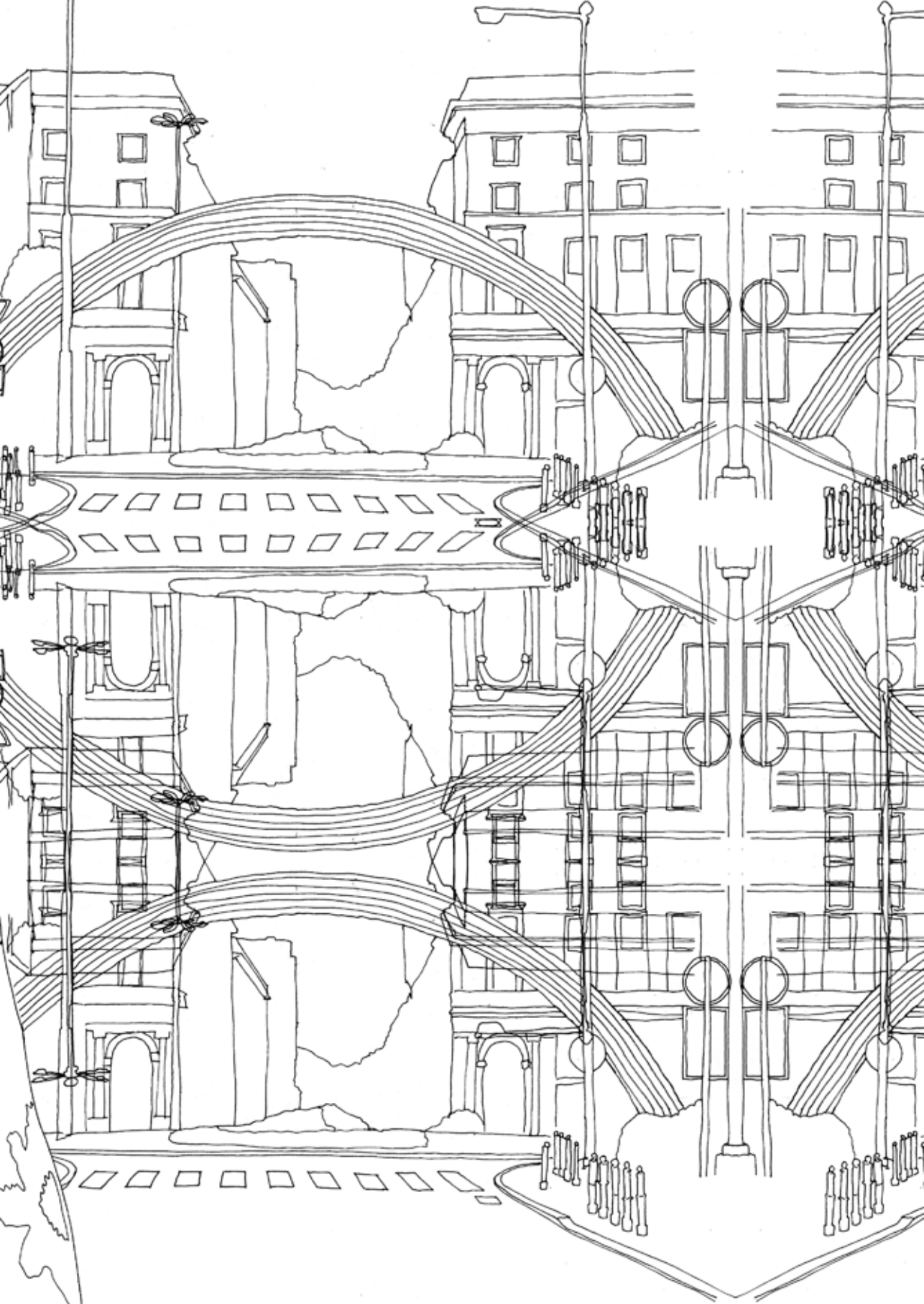

Agnieszka Kościanańska:

The spirit of an 'open church' has faded in Poland

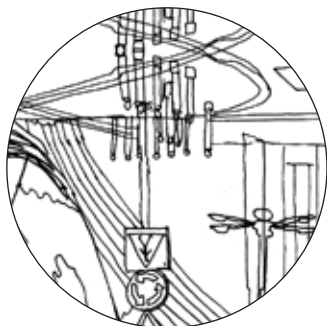

Agnieszka Kościanańska (born 1976), is an associate professor at the Department of Ethnology and Cultural Anthropology in the University of Warsaw. She is the co-editor of *Kobiety i religie* (Women and Religions, together with Katarzyna Leszczyńska, Kraków 2006). Recently she published *Płeć, przyjemność i przemoc. Kształtowanie dyskursu eksperckiego o seksualności* (Gender, Pleasure and Violence – the Construction of Expert Knowledge of Sexuality in Poland, Warsaw 2014).

How would you define religion?

We can define religion as a practice on an individual level – a way of organising the world, understanding and feeling things beyond comprehension, such as death, the presence of God or other non-corporal beings.

But we can also look at it from the perspective of rituals and community building. It is the ritual aspect that dominates in Poland – we baptise the children, have our marriages at church, and attend Mass – and that basically ends our religious practices.

What does religion mean for you – both in private and in public life?

Like almost everyone in Poland I was baptised after birth in the Roman Catholic Church. I spent lots of time in Podkowa Leśna – a small town near Warsaw, where my grandparents lived and many things happened in the local church during the 1980s which influenced my views on religion.

Each Sunday there were Authors' meetings – the church building, thanks to the local priest Kantorski (by whom I had been baptised), changed into a place of uncensored debate between both Catholic and secular intellectuals and artists. Even though I was too young to understand everything, I clearly recall the atmosphere of intellectual freedom, strongly contrasting with the situation in Warsaw, where armed transporters roamed the streets and military men controlled civilians.

This atmosphere evaporated quite quickly in the 1990s, when discussions on abortion erupted. I read confessions of women that were not granted absolution during confession due to using contraception (a 'permanent sin'), but got it after an abortion (as a 'one-time sin') or heard that they should give birth to their next children no matter what their state of health. The spirit of an 'open church' slowly faded, and my religious activities along with it.

You did a lot of research on the relationship between religious beliefs and practices and emancipation. What did you find out?

We are used to the leftist perspective on religion, which often looks at it as a sphere that limits our sexuality, discriminates against women or mutes class conflicts. Polish feminism often focuses just on the narrative about the Roman Catholic Church as an oppressor of women, influencing the enforcement of restrictive legislation regarding abortion or in vitro fertilisation, which violates the principles of gender equality and emancipation.

However in my research amongst deeply religious older women, who listen to the conservative, Catholic Radio Maryja, it turns out that it is more complex. They said they experience religious visions and possess the ability to heal other people. It helped them to gather authority amongst their relatives, in their local communities, and also to create new social bonds. Let us remember that it is a group that is not usually listened to and has limited social influence.

Another example worth mentioning is women that converted from Catholicism to other beliefs. I looked at a Hindu group called Brahma Kumaris that has clear New Age inspirations. It is a very emancipated group. The women that are its members have no problems with calling themselves feminists and declaring that gender equality is something that they strive for in their private lives.

We should therefore discuss if the Polish feminist movement

loses something with their current attitude towards religion and if a more nuanced position beyond a purely secular one would help it broaden its influence to other groups of women.

What do you think about the presence of faith and religion in the public life in Poland?

If we want to understand the context properly we need to look back at the 19th century, when not only the Polish national identity, but also the identity of the local Catholic Church took shape. Poland was not independent at the time and Catholicism was not dominant in two of the three empires that partitioned the country. The Polish church, with no official political power, had to rely on support from the worshippers. This led to a creation of mechanisms of survival that gave them authority in the society and thanks to which they became seen as the backbone of the Polish identity. These mechanisms gave the church a strong position even in times of the communist rule. It had to take their point of view into account – even though for example, abortion rules were loosened at that time.

We need to remember that the Polish church was much more democratic and open back in the 1970s and 1980s both compared to the present day and the public sphere back then. José Casanova wrote about it the book “Public Religions in the Modern World”. Democracy was being born in churches and the Catholic intellectuals’ circles, i.e. in 1987 the Catholic weekly *Tygodnik Powszechny* published a text *Poor Poles Look at the Ghetto* by Jan Błński, which sparked a debate about Polish anti-Semitism.

Even a large part of the women’s movement used the spheres of debate offered by the church. Sociologist Magdalena Grabowska, researching the origins of the Polish feminism, conducted interviews with its first leaders. It turned out that their activism was formed in the 1980s in the Solidarity movement, closely related to the church.

It sounds nice, but we know that there are reasons to be critical to the role of church in Poland...

In the 1990s, after the regime change, the role of the church grew. Its conservative wing was getting stronger – it could be seen in 1993, when a harsh anti-abortion law was passed. It allowed the termination of the pregnancy only when the life or health of the

woman is in danger; the foetus is irreparably damaged or is a result of a forbidden act, such as rape.

But even in the 1990s there were other, Catholic voices on this issue. Andrzej Wielowieyski – a prominent figure in the Catholic intellectual circles and a then MP – proposed liberalising the legislation, allowing abortion to be legal after medical consultation, and tried therefore to combine Catholic and liberal values. It was also a time of discussions about the new Polish constitution. The representatives of an ‘open church’ worked with their former enemies – the post-communists that had good electoral results back then – and together wrote its preamble.

Thanks to, for example, the first non-communist Polish prime minister after World War II, Tadeusz Mazowiecki, it focuses on a political nation comprised of both believers in God and those of us that draw universal values from other sources. But along with the growing influence of Radio Maryja and its director, Father Tadeusz Rydzyk, the conservative wing of the church grew as well.

What tensions are there between religion and the social and political life in Poland? How should the Greens respond to them?

Right now they are most visible in societal, sexual and reproductive issues. For two years we have heard about the dangers of ‘gender ideology’ aka ‘genderism’ – an example can be found in the Pastoral letter of the Polish bishops from late 2013: this ideology promotes principles that are totally contrary to reality and an integral understanding of human nature. It maintains that biological sex is not socially significant and that cultural sex which humans can freely develop and determine irrespective of biological conditions is most important. According to this ideology, humans can freely determine whether they want to be men or women and freely choose their sexual orientation. They wrote that this voluntary self-determination, not necessarily life-long, is to make the society accept the right to set up new types of families, for instance, families built on homosexual relations. According to them ‘gender ideology’ is a threat to the Polish nation. The representatives of the church that are more open to dialogue have been marginalised and the ‘church mainstream’ is right now extremely conservative.

Last year one of the most progressive Polish bishops, Cardinal Kazimierz Nycz, gave an interview to *Tygodnik Powszechny*. He argued that parents of homosexual children should invite them to

the Christmas table. The reactions of conservatives are not suitable for citation...

We should point out that a lot of arguments used by the right wing in Poland – contrary to their assurances – are not ‘traditional, Polish values’, but an import from the West. Attacks on ‘gender ideology’ come from works of German Catholic sociologist Gabriele Kubly, i.e. *Die Gender Revolution: Relativismus in Aktion*. The ideas of ‘healing’ homosexuals are taken from western psychologists, such as Paul Cameron, Richard Cohen, Alan Medinger or Gerard J.M. van den Aardweg.

The Left and the Greens, often accused of being ‘ideologies artificially brought from the West’ should reverse this narrative. They should show the Polish progressive traditions, such as the local feminist movement, ideas such as ‘a reform of the ways of life’ proposed by author Tadeusz Boy-Żeleński and emancipatory movements from the 1980s, such as *Wolę być*. Some support should also come from the growth of Catholic left – a combination of progressive views and Catholic tradition, pursued by, for example, the people behind *Kontakt* magazine.

In what ways can leftist and ecopolitical parties enter a dialogue with religious institutions and believers? Where to look for common ground?

How to discuss with each other and not forget about the differences?

We should differentiate between religious institutions and believers – in the latter group we can find a huge variety of opinions. Even though the church authorities are firmly against this, many believers do not accept the church doctrine on abortion and on contraception. We should remember about those differences. There are no reasons to think that a Catholic cannot be a Green or a feminist. It may sound utopian, but I would look for ways of finding common ground where it is possible.

The church will not accept abortion, but it may enter a common front against violence towards women. Already we can hear voices about ‘the sin of anti-feminism’, such as those voiced by Professor Ireneusz Mroczkowski from the Catholic University in Warsaw. There are also interpretations of vegetarianism/veganism as a form of asceticism – a practice looked favourably upon by the church. So, even though we speak in different languages and Catholicism does not often talk about the issue in terms of animal rights, we may try

to talk to each other.

Tygodnik Powszechny still is a place for such a dialogue. When the conservative priest Dariusz Oko talked about a 'homolobby' and likened emancipatory movements to the 20th century totalitarianisms, and *Fronda* magazine informed about ways of 'curing' LGBT people, the weekly mentioned above gave space for Robert Biedroń, the first open gay in the parliament, and criticised ideas of treating homosexuality as a disease or aberration.

It is hard to forget these conservative voices though...

There is a problem with people such as Oko, who are invited onto TV programmes so the ratings will grow. There is no possibility of discussion here, so you should not. What to do? It is hard to marginalise such extreme opinions, which show the role of educating journalists to be aware of potential discriminatory remarks and think about inviting not Oko, but priests more open to dialogue.

•

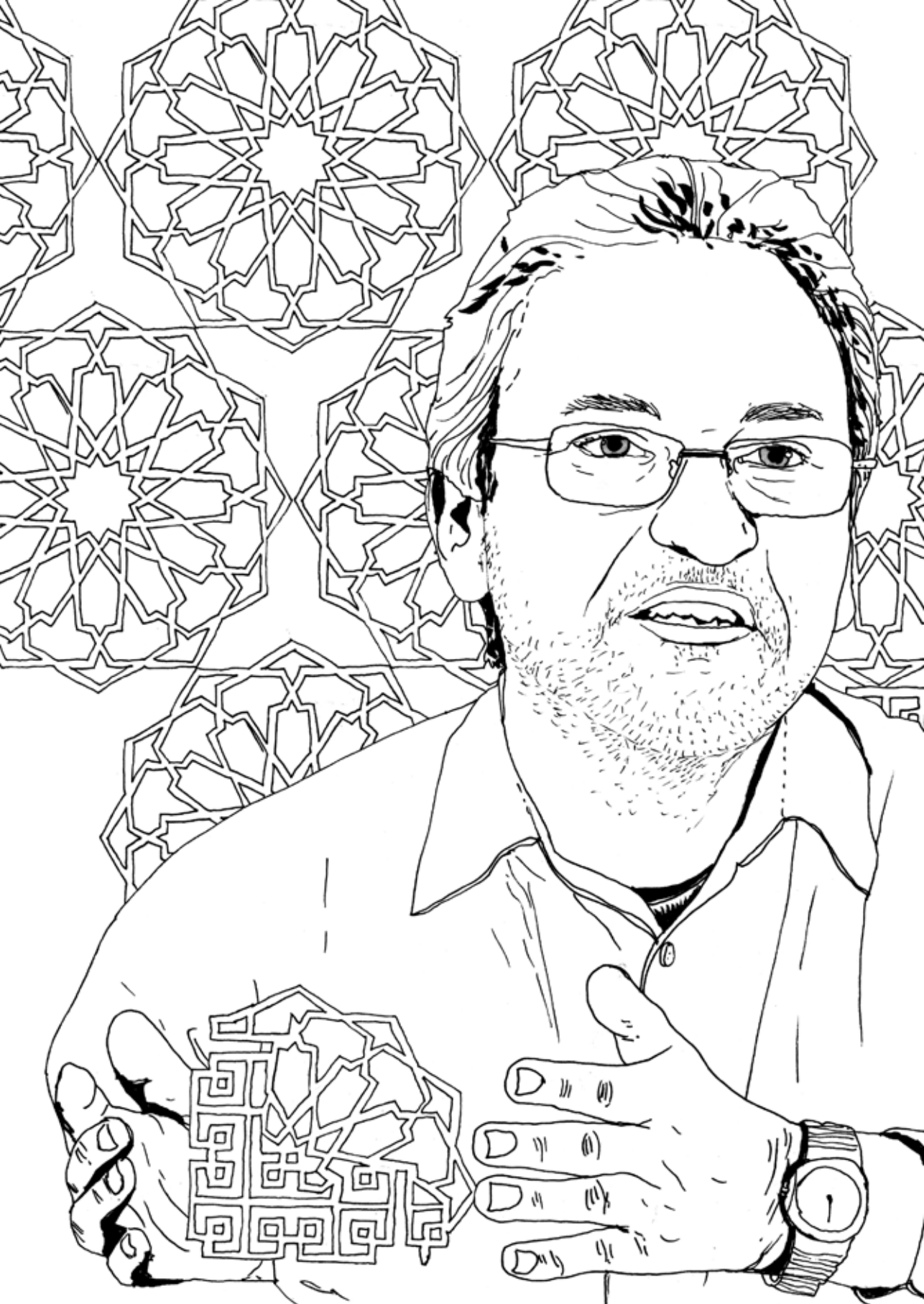

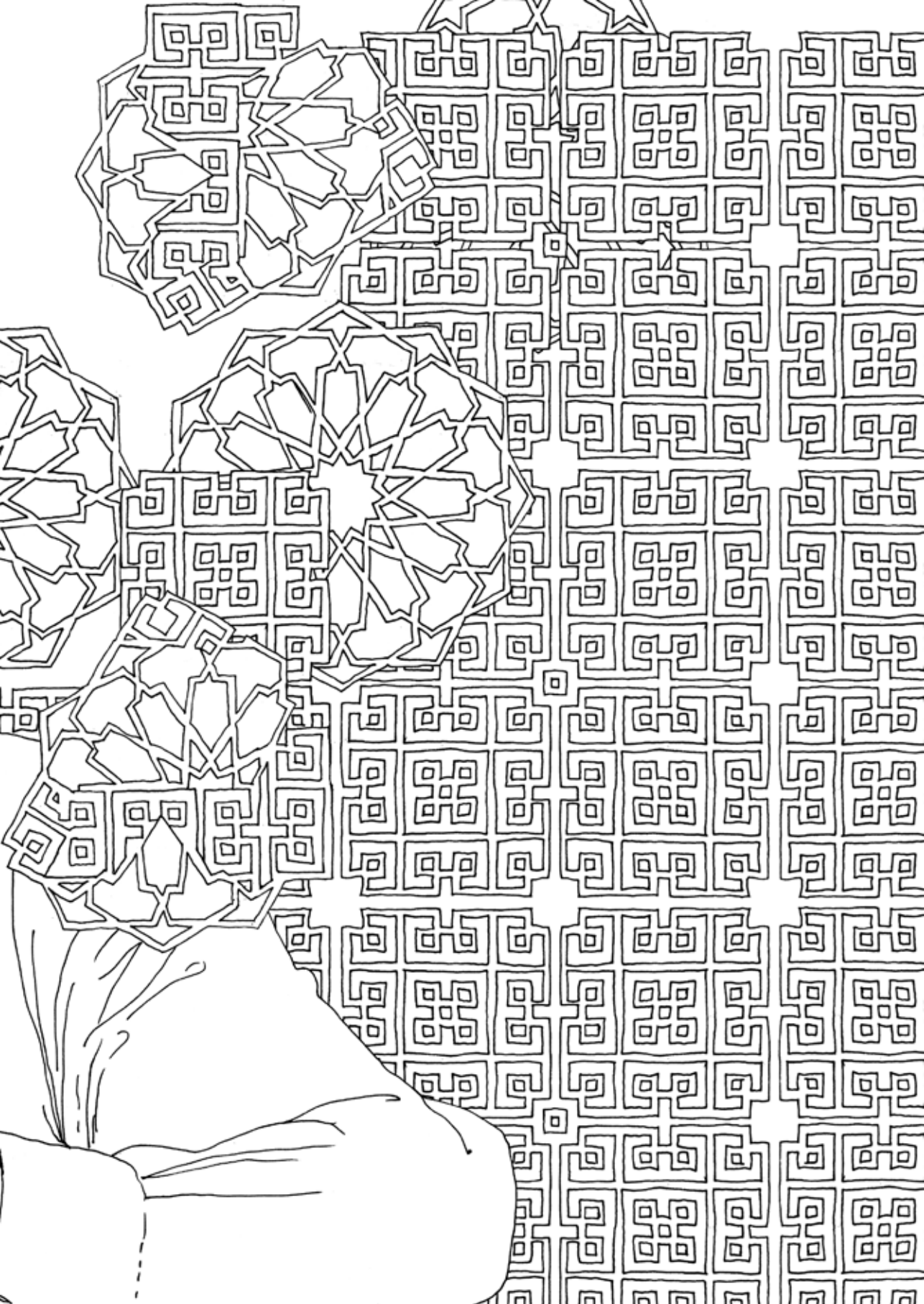

Yannis Paraskevopoulos: Religions are not immune to social change



Yannis Paraskevopoulos (born 1960) studied law and political science. He has been active in the Greek Green movement since the mid-1980s and has been particularly involved in Green Cities initiatives. He has been active as a grassroots trade union organizer as well as an anti-globalization activist. He has published numerous articles including Green cities, sustainable transport, globalization, nationalism, the Green-Left relationship, as well as Green answers to the Greek crisis. A founding member of Oikologoi Prasinoi, the Greek Greens, he has served as party coordinator (2005-7), party co-spokesperson (2010-11) and top candidate in the 2012 national elections party list. He has also worked to support the presence of Oikologoi Prasinoi in the European Parliament (2009-2012).

How would you define religion?

In defining religion, I would opt for the broadest possible definition: one that includes not only collective institutionalised faiths and individual spirituality, but also the projection of religious traditions on current secular attitudes and ways of thinking. The negative perception of debt and the obsession with money and how it is used by northern Protestant Europeans, the emphasis on ethics in societies with a Catholic tradition, the priority of social coherence by conservative movements in the Muslim world, can all be associated with this kind of cultural religious background.

I also think that, in Green politics, religions should be viewed in their dynamic dimension: their multiple aspects – potentially

antagonistic to each other and open to different interpretations – make them open to broader social evolution. Religion can be likened to a musical instrument on which you can play a rather broad spectrum of music, regardless of the kind of music it was originally intended for.

What religious or non-religious tradition do you come from?

What does this tradition mean to you in your public and personal life?

Are they related?

I grew up in a religious Christian Orthodox family. My childhood was traumatised by my parents being recruited by a fundamentalist and influential religious organisation, loyal to the Orthodox Church but deeply influenced by the Catholic Opus Dei and Protestant pietistic movements. I never identified myself with this version of religion, but it took me several years of personal search before I found out what I really wanted to stand for.

As a young student in the 1980s I observed with interest the intellectual movement called the ‘Neorthodoxoi’, who then sought to underline the cultural and philosophical aspects of orthodoxy as a bridge between East and West, and to facilitate a new synthesis with the socialist imperatives. For the last twenty-five years I still respect Christian Orthodoxy, but I feel myself rather religion neutral in my personal beliefs, and I leave these questions more open.

How is your set of values or your religious belief related to being active as a Green activist and politician?

When I first joined the Green movement in the early 1980s, I was still thinking of myself as a Christian. On the other hand, I had already participated in the 1979-80 alternative students’ movement (the closest Greek equivalent to 1968), and the Green movement appeared to me as an obvious next step to fight to change the world in that same direction.

In this context, I looked forward to Green thinking as an interesting new synthesis, effectively integrating vital elements from Marxism, Anarchism and Christianity. It also appealed to me that, contrary to previous radical political traditions, the Greens had no party doctrine about religion and were equally open to activists regardless of their religious or non-religious beliefs. The Green concept of personal and collective accountability, whether towards our fellow Greens, the broader society, the planet, or the future

generations came easily to me as a secular projection of religious moral responsibility.

My ties to religion are now much more remote. The openness of the Green movement towards religious and non-religious beliefs somehow reflects my current personal religious neutrality. Nevertheless, I feel that my previous experience and my potential to understand religious people is still an asset to me as a Green activist. Greece is still a largely conservative country where important Green issues, such as challenging nationalism, defending gay rights or advocating separation of church and state, can sometimes be very sensitive.

Being able to talk and debate with conservative people in their own language without compromising our Green values, can sometimes make a great difference. Having a deeper understanding of their concerns can help. To give just one example, in a country where many gays and lesbians are still under pressure by their parents to get locked into a 'showcase' conventional marriage just to cover up their sexual orientation, a large part of conservative audiences can be open to the argument that marriage equality can also help prevent this kind of failed families, which trap and ruin straight people as well.

What is your personal experience with religion in public space and in the public debate?

In Greece the Orthodox Church has traditionally a very strong role in public life: besides its constitutional status as the established religion of the state, the church leadership is rather viewed by both religious and non-religious citizens more as informal parallel authorities than as spiritual figures. A large part of the clergy often appears as the custodian of Greek nationalism. While 70% now appear in polls to support a church-state separation, up to 50% of Greeks are estimated to be still directly influenced by the Orthodox Church. Politicians often demonstrate loyalty to the church or ties to local priests and bishops, as a safe and effective way to get a competitive edge in getting elected. Even the communist left has constantly shown respect to the church, while an anti-clerical movement has only appeared in the last fifteen years, after a series of aggressive attempts by a controversial former archbishop to further expand the public role of the church.

Few people are aware that these patterns date back to the Ottoman rule, where ethnic communities were demarcated through religious faith (millet) rather than through language or ethnicity. In that system every millet was represented in the state via its respective religious leaders, with Greek-speaking Muslims in Crete and Cyprus having therefore the status of Turks, while Turkish-speaking Christians in central Anatolia were treated as Greeks. In the Orthodox millet, which also included the other Orthodox Balkan people as well as the Middle East Orthodox Arab minorities, Greeks had for centuries a dominant role. In this context, modern Greek nationhood was based to a large extent on loyalty to the Greek Orthodox church thus easily including and integrating a large spectrum of linguistic diversity, as diverse languages including Albanian, Slavic-Macedonian and those of Italic and Turkish origin were widely used into the early 20th century among populations identifying themselves as Greeks.

The church and the local clergy can sometimes be a crucial potential ally for environmental and human rights issues. Since the early 1990s, the prestigious Orthodox Patriarchate of Constantinople (Istanbul) has put environment high in its agenda and adopted a Green rhetoric, although it has hardly reached the national church of Greece. However the church can also be a fierce opponent, when it feels its public role is threatened or when it comes down to interests of their own, like developing huge church buildings in protected areas or teaming up with private investors to develop huge hotel and golf course complexes in arid monastery lands. In our Green campaigns there are eloquent examples of both.

What position should the Greens choose toward the church, if she can be both an ally and an opponent?

Nevertheless I think the real challenge for Greek Greens is to put forward a roadmap towards a new role of the Orthodox Church, from a traditional deep state link to part of a developing civic society. Engaging large parts of religious conservative audiences in such a dialogue demands that we Greens realise that it is not a question of whether we 'like' or 'dislike' the church and whether we work to 'support' or to 'marginalise' it. The right question is which actual reforms we are putting forth and whether we are open to show respect to people of religious belief and include them in this dialogue.

These challenges have been also reflected in our collective experience as Greek Greens, in the May 2012 national election. In the Northern Aegean constituency of Chios, where the local clergy association had publicly asked all candidates to disclose their positions about a series of demands by the local priests, the Chios Greens published an open letter stating their respect for the social work of the church, but still insisting the church should also be fairly and proportionally part of the effort for additional public revenues to help exit the crisis. In that election, the Chios Greens scored our second highest result nationally.

It is important to understand for Greens that religious people usually experience their faith not just as answers about God, but also as a source of a distinct cultural identity as well as a refuge in times of uncertainty and social exclusion; Green ideas regarding decoupling prosperity and social inclusion from economic growth and individual purchasing power could facilitate a fruitful public dialogue. Religions are not immune to social change. If Green values such as sustainability and human rights continue to gain ground across Europe and the world, large parts of religious people of every faith would then be motivated in the long run to have these values embedded into their respective religious cultural traditions also. Seeds in this direction already exist in every major religion I know. In this context, the long-term vision for us would be to make sustainability and human rights a common ground connecting distinct religious and secular identities within coherent multicultural societies.

How do you see the place of Islam in Europe?

Islam is not something new to Europe. Essential features of the modern European civilisation and culture, from algebra to the rediscovery of Aristotelian philosophy, have all arrived from the Islamic world. Like any other major religion, Islam appears in lots of different and often conflicting versions, as different to each other as are the sects of Christianity.

To seriously debate the place of Islam in modern Europe, we have to confront our own stereotypes first. For example: Back in 1900 most Europeans thought of Islam as a religion of lust and sensuality as it accepted polygamy, now most of us think of it as anti-sexual.

We now think Islamic culture is inherently against the emancipation of women, but in 1000 AD there were more emancipated women in the Islamic metropolises of Cordova and Baghdad than in the whole of Christian Western Europe.

When labelling Islam as intolerant, we should remember that for more than one thousand years it has been the most tolerant of all three monotheistic religions.

We usually think of Islamic culture as incompatible with cosmopolitanism and economic prosperity, but the Greek bourgeoisie in the 19th century was flourishing much more in Istanbul, Izmir and Alexandria than in Athens.

In current human rights issues, we often tend to focus much more on violations in anti-western Iran than in pro-western Saudi Arabia which nevertheless appears to share the same Wahhabi intolerant theology as ISIS.

We do not make the link between the rise of political Islam and popular discontent about the abandonment of the Zakat, the religious solidarity tax by westernised upper and middle classes in the Islamic world without this being replaced by any kind of effective welfare state.

An open dialogue is indispensable for Greens in order to bring forth fruitful answers to the new challenges presented. These challenges cover a wide spectrum of experiences, from South-Eastern Europe where Muslim communities are mostly native and have a tradition of peaceful co-existence with Christians, to Mediterranean Europe countries serving as 'entry gates' of the refugees to Europe, to Northern Europe coping to integrate second-generation immigrants or discontented newly converts to Islam. Besides promoting social inclusion and fully respecting religious and cultural diversity without compromising human rights, we face a much bigger challenge: to develop new models for expanding the influence of Green ideas beyond the western/Christian world and for them to flourish among the huge populations of the Muslim world.

Starting points for such a dialogue could include the traditional Islamic reverence of water, the emphasis on redistribution such as emphasised in the Zakat and the ban on interest, the threats climate change poses to Islamic countries. In the early 2000s the Green movement was the first to champion the Dialogue of Civilisations, and we have to keep working and building on this.



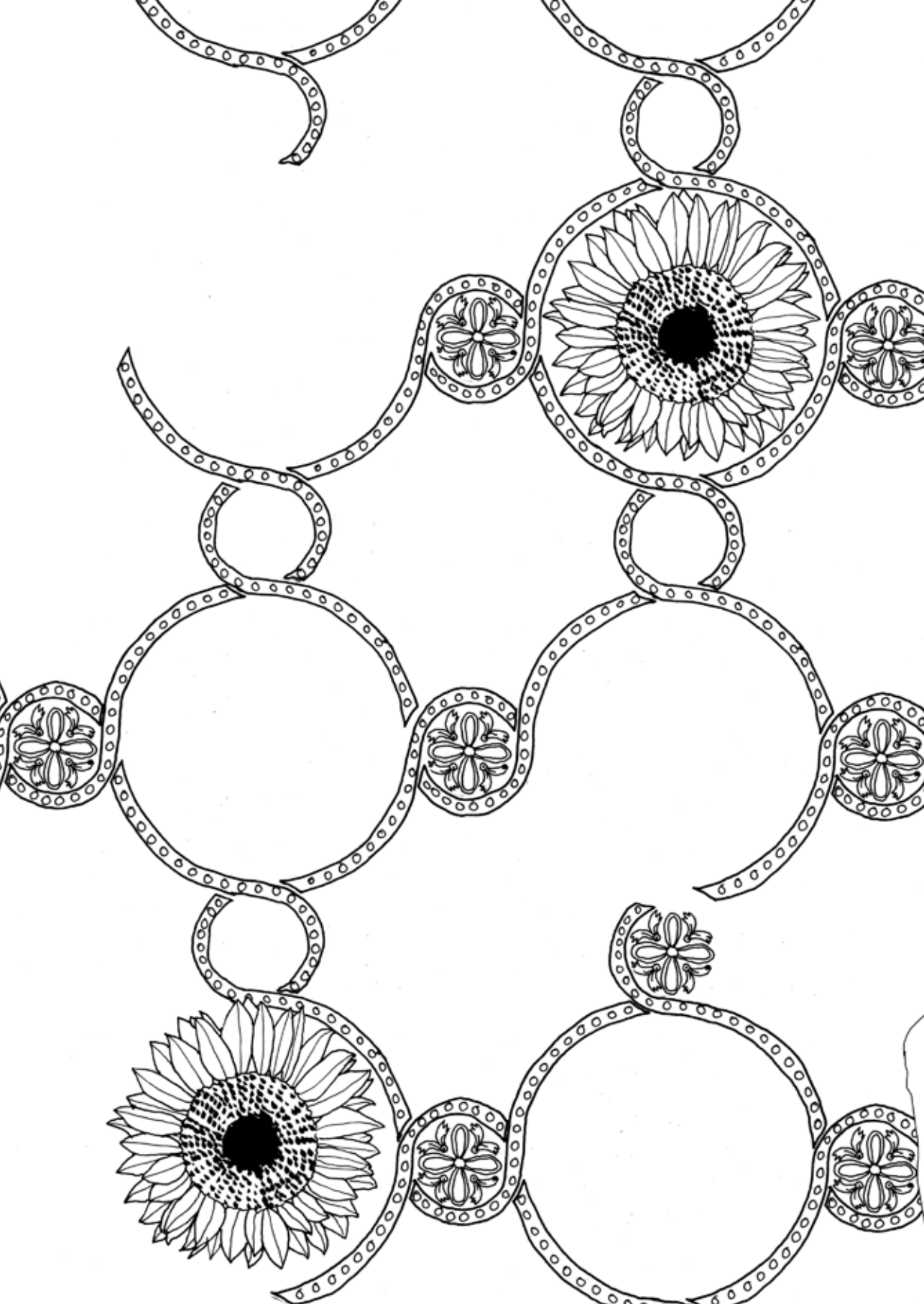



Giorgos Dimaras: Greece must separate church and state

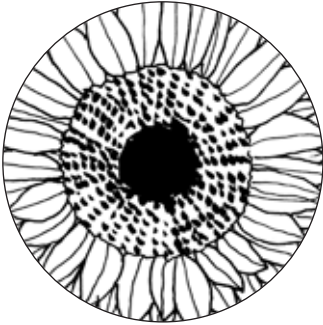

Giorgos Dimaras (born 1947) studied civil engineering and economics at the University of Athens and subsequently started his own technical consulting company. He was actively involved in the struggle against the dictatorship. Dimaras was a member of the Communist Party until 1985 and a founding member of Oikologoi Prasinoi (the Greek Green Party) where he served on its national council and executive secretariat. Dimaras was a Regional Councillor of Attica (2010-2014). In January 2015 he was elected to the Greek Parliament in a coalition of Oikologoi Prasinoi and Syriza. He was re-elected in September 2015.

How would you define religion?

Religion is the timeless human need to believe in some higher metaphysical force which explains the genesis of life and gives meaning to life on earth. As an ecologist, I believe that the miracle of life is something superior to us and that we have a duty to respect and to protect the right of life for all living organisms.

I grew up in a rural community with a strong left background and ideology, both in terms of resistance to Hitler's Nazism and to the Greek dictatorship in the 1960s. Therefore, faith in religion and the relationship with the clergy was cautious. In my family, my wife and myself instilled in our three children, through their upbringing, the right to decide for themselves regarding their religious beliefs.

However, in Greece religious traditions and rituals are deeply

rooted in history, relate to local traditions (with many surviving from ancient times) and perform a social function. Personally, I participate in many rituals during religious and national holidays with my family and friends, especially in my homeland of Agios Georgios Messolongi. I think that religion can operate positively for people by bringing messages of peace and love; but it can become a weapon of fanaticism and exclusion, when religion becomes a symbol of war, something we see today with the jihadists. Hence, as politicians we have a responsibility to treat the issue of religion very carefully within our public discourse and to separate it from politics and power.

What experience do you have with religion in the public space and in public debate?

In Greece, friendly attitudes to the church and religious feeling are reflected in the entire political spectrum from the left to the far right. As an active member in left politics and later as a founding member of Oikologoi Prasinoi, I was critical of the conservative views of, and the compromises with, the church – no matter where they came from. I take a contrary position to both public interventions from ecclesiastical functionaries in public policy issues and the manipulation of the masses to demagoguery and populism of politicians and political parties.

Recently, because of the financial problems faced by the Greek state, which is in search of funding sources and is taking tough fiscal measures, the issue of church property has emerged along with the taxation of church and the separation of church and state by revising the Constitution. Despite the long standing call for church-state separation in Greek society, politicians who come to power do not venture to break the ties with the church and the privileges of the clergy, fearing the political cost.

Actually, a central issue in the public discourse, which has created controversy among political parties, is the discussion regarding religious instruction in public schools. I submitted a written question to the Greek Parliament and requested that the Minister for Education reduce the hours of religious instruction, which could be replaced by other options for the students, and add hours on environmental education.

What actual debates exist on the relation between church and state, and

what is their historical background?

In recent years in Greece after a period of slackening, the church increased its influence, even after the new modernisation initiatives. The doctrine of a Greek Orthodox unique ethnic group which cultivated an ethnocentric perception, found support from the intellectual movement, the so-called 'Neorthodoxoi', who supported anti-European positions several times in the 1990s. The revival of religious ethics gave new power to the Greek Orthodox church, whose many supporters are engaged in public interventions on foreign policy and other public issues, influenced by propaganda from the pulpit on various secular issues.

The church came to meet the spiritual needs of the Greek people, who were morally tired, in a transition from a traditional lifestyle to a modern and globalised environment, which they were not ready to accept fully. The religious revival has resulted in a conservative turn of Greek society to old fashioned values, like nationalist and conservative values. For example, a large protest organised by the church and demonstrations against the new identity cards which did not have a reference to the Greek Orthodox identity.

The strong influence of the church in Greek society has historical roots. The extensive church property is a remnant from the Ottoman Empire, where some property remained in the hands of religious communities (milliyet) and their management was invested in their religious leaders and spiritual shepherds. Church property remains uncharted and the church's contribution to tackling the Greek crisis is limited to charitable actions, like providing rations, shelter and support to poor citizens.

Greece has not achieved the institutional separation of church and state. In fact we cannot talk about a secular state – we have a religious oath, priests paid by the state, government officials, and religious courses in the school curriculum.

Do you regard religion as a source of inspiration or an obstacle for Green politics, and how?

I believe that religion can be a source of inspiration for people with environmental sensitivities, insofar as the ecological view, like the world religions, considers humans as part of a whole, the universe, the creation of which surpasses the person, existing

before and after the person. Also, both ecology as a worldview and religion have an ecumenical character, and promote universal and humanistic values. In this sense, they are complementary insofar as they respect the faith of other peoples and religious minorities without fanaticism and intolerance.

What conflicts are there in your context between fundamental rights, like the freedom of religion and the principle of sexual and gender equality? Should Greens tolerate views which are intolerant of equality and emancipation?

The central theme in the discussions of the Green Party in Greece, which we demand of the government, is the construction of a public mosque in Athens, for which recently the new government has decided on the site but not yet started its construction.

The building of a mosque comes up against reactionary forces supported by nationalists and fanatical Christians. Another issue that divides is that of homosexual couples and specially the change of the law on inheritance rights and adoption possibilities. A third issue is the course of religious catechism in schools and the content of these courses, which should be changed, because it contains out-dated concepts regarding gender relations and abortion. I believe that Greens should not be tolerant of views opposing equality and they must encourage dialogue with civil society in order to alleviate fears and prejudices that are stronger in times of crises and insecurity.

How do you see the place of Islam in Europe?

As Greens, we believe in multiculturalism and tolerance.

Moreover, the presence of Islam in Europe has historical roots; Eastern and Southern Europe have Muslim populations, but also citizens of Western European countries with immigrant origins (France, Germany, etc.) are Muslims. The composition of Muslim populations will increase with the arrival of refugees in Europe. The doctrine of the clash of civilisations is against our position and we believe that the jihadist violent behaviour should not undermine the European tradition of religious freedom, tolerance and democracy.

The promotion of respect for the rights of minorities, be they religious, ethnic, linguistic or gender, was one of the reasons why we won as ecologists. The issue of religious intolerance will face

increasing tension with the new migration flows and the recent stream of refugees from war zones. I believe that the future will vigorously test our strength and sincere belief in human rights.

How could Greens respond to those challenges?

The combination of economic crisis and increased refugee and migration from war zones creates a favourable ground for right-wing parties and a xenophobic, intolerant and conservative rhetoric, which the Greens should address by highlighting the real causes, the ecological and social dimensions of conflicts, and the responsibilities of the powerful. The Greens should promote dialogue between religious communities and require that governments protect religious minorities. To religious communities, the Greens can offer the values of tolerance, understanding and solidarity in a common human community, which lives in harmony with the natural environment and which offers lifestyles which are different from those of consumerism, nationalism and aggressive neoliberalism.

Greens also see the need for Europe to take an active role in resolving conflict and bloody wars where fundamentalist religious groups are involved, leading to the uprooting and death of persecuted, desperate people, who are victims of religious fanaticism.

•



Savaş Çömlek:

Make space for a colourful understanding of religion



Savaş Çömlek was born 1966 in Konya where a number of Sufi leaders including Mevlana lived. In 1985 he began Medical School at Istanbul University. He lives in Istanbul and works as an anesthesiology and intensive care specialist at a private hospital.

Savaş was introduced to Green thought by reading the works of Rudolph Bahro and Ivan illic. His political life began during his university years as an activist in various student associations which, in the aftermath of the 1980 coup, were among the few legal sites in which left wing opposition struggled. He became co-spokesperson of the founding initiative of the Green Party in 2008 and he seeks to contribute as an activist to all sorts of activities of the Green movement.

How do you define religion?

My definition of religion often changes but my latest one is this: religion is an ancient system of knowledge created as a defence mechanism against human beings' existential and evolutionary pains.

Which tradition of belief or non-belief do you come from? What does that tradition mean to you in your private and public life?

I come from a context in which there was a considerable clash between my family and the surrounding social milieu, believers in Sunni Islam. In my own family, religion was not too important, but family elders were following religious rituals.

When I was very young, life was very different. We lived in Karaman-Ermenek in the northern parts of the Toros Mountains. In the village of my childhood in the 1970s, many old religious traditions were still alive. The influence of Sunni Islam was limited mostly to prayer rituals on Friday and holiday prayers, and to the mosque. The daily rituals of the village life were woven with religious and cultural practices, the origins of which go way back to the distant past in the Anatolian Plateau, the pre-Islamic past from Hittite, to Greek, to Christian. They had left a corresponding imprint in social life. For example, the Christian Easter ritual had an equivalent in the village: children used to steal eggs. We also used to celebrate *hidrellez* and harvests. They used to cook *pişi*, which is a kind of pancake, and it is a tradition which goes back to the Hittites. It is still done by the Alevi and, although there weren't any Alevi living in our district, cooking *Aşure* and *pişi* was a must.

But things changed at the end of the seventies. In the eighties, we experienced a serious social trauma. All religious communities became more influential throughout the country. They were tolerated and even supported by the military regime. The 'struggle against communism' was the big idea for the military and, probably because of that, the military regime opened the way to the religionists. And all those colours and traditions of village life suddenly disappeared as if scythed overnight.

Did this change happen in a natural way or did the people feel pressured?

There was a clash of ideas. For example, the most significant event in my childhood was the arrival of the TV. Ours was the first house into which TV entered. My parents were teachers of the village. During a Friday sermon, the village Imam declared the TV to be an evil instrument and all hell broke loose in the village. It was a period of serious polarisation between Sunni Muslims and those who, coming from a socialist, progressive tradition, did not accept or did not care about the Sunni faith. For example, there was often tension in the mosques about whether their funeral ceremonies should be performed or not. The TV story was the second big issue. It ended like this: the Imam, whose son was a friend of mine, went on a pilgrimage to Mecca and came back with a TV. In fact, those tensions can also be read as certain pre-modern understandings resisting modernism for a while.

How did you experience all this?

As I said, my family was not very religious. We did not fast; however every Ramadan, we used to go to sleep with the lights on to give the impression that we woke up for the pre-dawn meal. But still, there was a lot of tension. Much of it was created because of my mother. She was a teacher and the only uncovered woman in the village, who dressed in a modern style. My father was the son of one of the more prominent members of the village community and he used to give my mother advice like: “why don’t you cover just a little?”, but my mother was uncompromising. This issue of religious covering caused a lot of tension in the house; it was the nightmare of my childhood. It marginalised us socially: the whole family was excluded from certain rituals. These things happened at the end of the seventies. Before that, there was no such discrimination.

I entered university in 1985. Since there were very few state-run hostels, there were only two options: living in one of the houses or hostels of the religionists, or renting your own apartment, which was too expensive. My father sent me to one of the religionists’ hostels; a lot of students become religionists like this, they help you with housing and provide you with social company. When you came from a rural area, Süleymanist and Gülenist hostels made it possible to go to school or to university. The Süleymans follow the teachings of Süleyman Hilmi Tunahan, a Sufi teacher. The Gülen movement is led by Fethullah Gülen and is very active in education and interfaith dialogue. In the end they follow the teachings of Said Nursî, although they interpret him in their own way. All those communities are the bearers of the understanding of Islam of modern times and therefore there are serious tensions between them and the traditional *tarikats* or religious orders. In my interpretation at the time, I found Sufism somehow more colourful. Said Nursî’s books are valuable, but I did not find them attractive at all, because they were based entirely on reason. They did not have the depth and infinity of Sufism, and it appeared to me as if there was something missing in them. However, I was accepted in a Gülenist house. They provided us with food and helped with a lot of things, making life quite comfortable.

I received a scholarship from an organisation called *İlim Yayıma Cemiyeti* (Association for the Dissemination of Wisdom). It was

established as an association to struggle against communism, and the overwhelming majority of conservative bureaucrats who are now in prominent positions have been, at one point or another, in touch with it. The Gülenists expected you to distribute magazines and teach children. I listened to their cassettes and went to meetings. Now they have TV channels to spread their message. They invited me to participate in prayer and to sing the *azan*. I didn't do it, and nobody forced me. After three months I managed to get into a state hostel, but I had a good time with the Gülenists. Once I was in the state-run dormitory, I became a founding member of the Students Union. The Gülenist once said to me in my father's presence: "Savaş, you were supposed to become the next Imam of Istanbul, why did you leave us?". They tried to maintain their contact with me, but it didn't work.

How do these values and beliefs of yours relate to your Green activism or politics?

As I told you, the religious and cultural values I experienced as a child belonged to a kind of Mother Nature culture. My maternal grandmother used to tell very beautiful fairy tales. It was as if those tales, from *Layla and Majnun* to the tale of *Basilisk*, were integral parts of my life. We should not talk of one single religion only. This state of multi-colourfulness, of the co-existence of many different cultures, the happiness of the childhood, the harvest rituals, childhood games, stealing and collecting eggs, *hidrellez* celebrations... I guess the concept of the convivial society, the convivial politics of life, which I found in Ivan Illich's books when I encountered them much later, had a corresponding counterpart in Green activism. Perhaps it was because I grew up in a mountain village that there has been always a connection with nature.

In Anatolia, many different, colourful understandings of religion, which are never, ever uniform, live together. This rich, rainbow-like diversity of religions is still alive in Anatolia. I believe that Green politics, with its emphasis on liberties and the co-existence of different cultures, can offer just the right understanding and sympathy for this diversity to flourish. In that way, the Greens have a perspective which can offer a solution to serious clashes stemming from religious differences.

In Turkey, from the very beginning, there has been a clash between the official ideology of the republican regime and the reli-

gious communities. There is an official understanding of religion. In the Middle East, religion is an important determinant in social life. Without dominating religion, it is impossible to dominate the state. States cannot be without religion. Therefore the founding reason of the Turkish republic probably found it necessary to control religion. There is an official organisation, the *Diyanet*, created just to control religion. I can recall the clash between the government officials of the *Diyanet* and my Süleymanist uncle from my childhood.

The Greens have the opportunity and potential to develop significant political ideas to solve such clashes and to create a more peaceful, more colourful social life. The majority of our members are western-educated people who have not much relationship with religion in a traditional sense. But the relationship between freedom and religion has always been one of the important subject matters for the Greens. I feel the values of the pre-modern times I experienced in my youth overlap almost one-to-one with the sources of the Green thought. There is no reason why they cannot act in concert.

What are the fundamental conflicts between religion and society?

How can the Greens respond to those conflicts?

The most significant problem is the fact that there is an official understanding of religion; people feel that, alongside their very real, living beliefs, there is also an official version to which there is pressure to conform. The pressure the state establishes through religion colonises all aspects of life. That is one of the fundamental conflicts in society. The second is the fact that particular Sunni movements under Wahhabi-Salafi influence have a method of celebrating violence, and bulldozing and expunging different understandings of religion. This is the second big threat. The Greens should struggle against both types of pressure. This is the only way to establish real relationships with society. This is the only way to realise our utopia of a peaceful social life.

The Green Party's position from its establishment onwards was to side with methods of solution promoting social peace and excluding violence. A good example of resolving religion-based clashes in the public space was during the Gezi Protests in 2013, when demonstrations around the Gezi Park in Istanbul for freedom of the

press, of expression and against the government's encroachment on secularism were violently suppressed. The good thing about Gezi was that religion appeared in spheres and forms other than those controlled by the state, not as something emphasising wealth and grandiosity, but as something emphasising humility, tolerance and compassion – for example, the *Yeryüzü Sofrası* (Earth's Surface Table) rituals have become a source of hope for a wide segment of society. People saw that religion can exist without necessarily representing the official authority. This was the only way to solve the problem of the hostility of the leftists against religion. What must be emphasised at this point is that religion is not one thing, but it is something that is composed of many things. And I think this is important, this is how we must see it.

How do you see the place of Islam in Europe?

From 2008 onwards, the European Greens have already predicted that, from their perspective, Islamophobia will become a major problem. They have struggled very hard against Islamophobia as a form of discrimination. Therefore I don't think the Greens will have any serious problems, at least with the Muslim intellectuals. I don't think the Greens and those accepting the Green worldview would have serious problems with Islam.

Until a hundred years ago, the Muslims and Christians in Anatolia had very close relations. Everyone would go to each other's churches or mosques. For example, those who congratulate me on religious days are mostly people believing in other religions. It's incredible.

We can say that it is against violence. The more pro-freedom interpretations of Islam must be supported. Everyone should know that there are such differences in Islam, that there are different interpretations and understandings of Islam – this is perhaps one of the most important points of the struggle, along with that of public awareness raising.

•

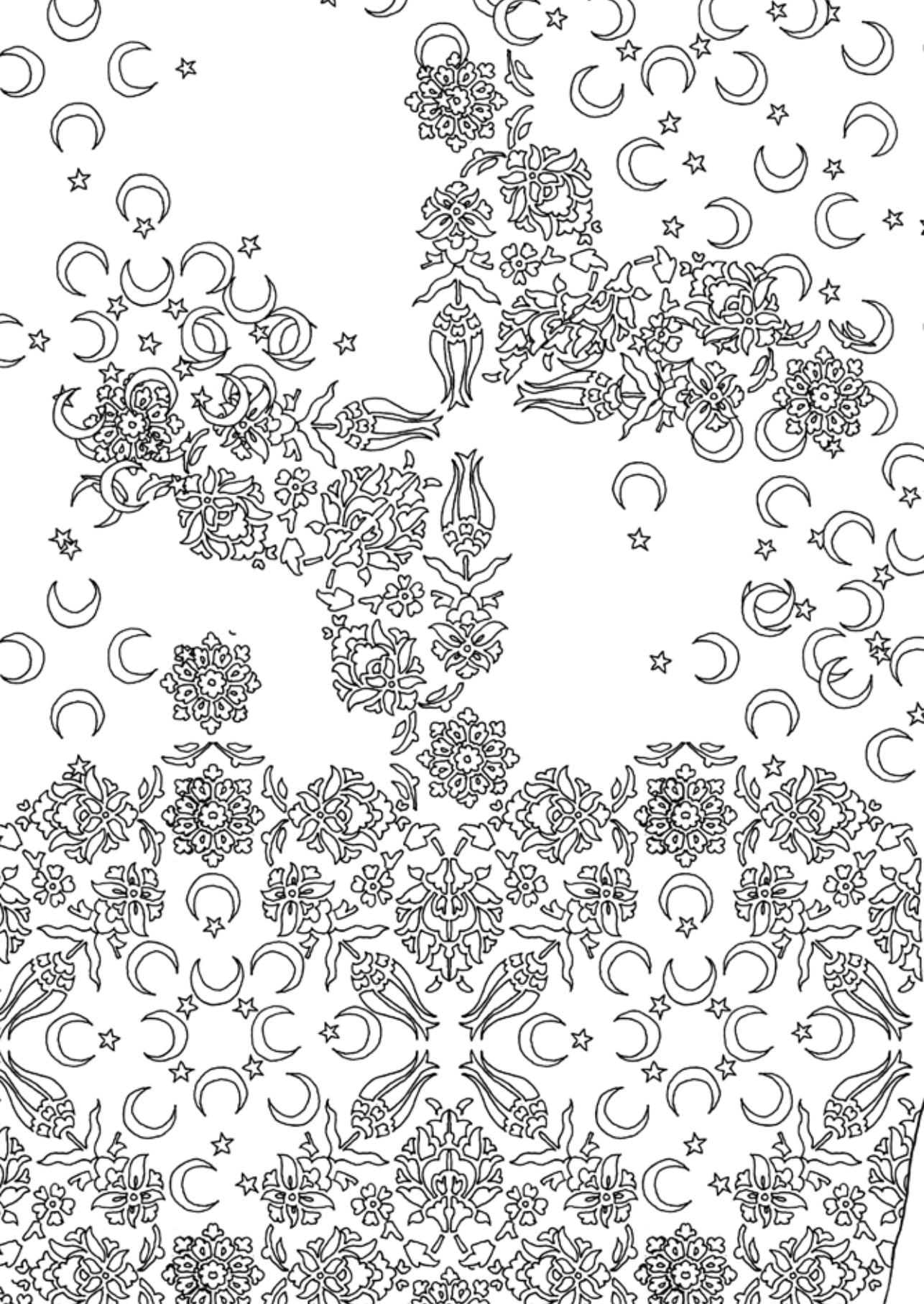



Nil Mutluer:

Secularism in Turkey is not freedom, but control of belief



Nil Mutluer (born 1974) is Head of Sociology Department at Nişantaşı University Istanbul. She studied international relations at Bilkent University and cultural studies at Istanbul Bilgi University. She did her PhD in Gender Studies at Central European University in Budapest. She also teaches a course on Human Rights and Democracy at Getronogan Armenian High School in Istanbul. Mutluer is one of the founders and an elected member of the party assembly of the Green and Left Future Party in Turkey. She is also a member of the executive board of Helsinki Citizens Assembly and of the consultancy board of the Association for Supporting Women Candidates. She has edited books and wrote articles on gender, nationalism, belief, everyday life and urbanization.

How would you define religion?

I define religion as a personal and private matter, but it is obvious that it has a sociological dimension as well. Personally religion is, for me, the projection of conscience, ethics and balance onto my inner world. However, religion also shapes societal values within a framework of power relations by determining the meanings people attribute to morality. That religion is not independent of power relations and politics prevalent at a particular time and place is an undeniable fact. Even if social rules are determined by holy books, especially those of the monotheistic religions, how these rules are interpreted and applied to particular cases in everyday life depends on the time and place.

What experience do you have with religion in the public space and in public debate?

I grew up in a secular family, at a time when the secularist hegemony was still intact. At that time the main discussion, the main fear, was summarised with the word “irtica”, which means religious reaction – the fear that Sharia will be reinstated and the so-called “religionists” will get the lion’s share from the economic resources, etc. But in time, when I was introduced to critical thinking, I realised that this fear itself was a reflex that was developed and kept alive to protect the established order of the state. In Turkey, laicism or secularism has never been based on an understanding of freedom of religion and belief, or of keeping religious and political affairs separate from one another. Quite the contrary, it was based on an attempt to reform religion and re-impose it as an orthodox ideology allowing no dissent. I became curious about how different religions could ever have existed here, and I realised that a number of my friends, and even my own family, had been quite literally assimilated into that imposed mainstream. I also realised that other religious understandings are either banned or relegated to an inferior status by the state, and nothing much has changed in the republican era in terms of the freedom of conscience and religion.

After the 1980 coup, political Islam became more dominant but, because of the internal tensions within the state, the head-scarf was banned, and that ban became a major obstacle for women getting an education. Since the practices of the more religious people fell outside the accepted, uniform understanding of religion, they were treated as second-class people and the head-scarves of the Muslim women have become the latest area where this tension and clash between the secularists and the religionists have taken place.

When I was a university student I witnessed how those women were marginalised, which encouraged me to investigate the issue more critically and I became one of the supporters of the freedom of Muslim women to wear the Islamic head-scarf in the public sphere in general and public education in particular. It was for me a difficult period of transition – I mean I had to raise my own awareness and I had to fight my own phobia, but I reached a point where I now see and experience quite clearly that, if we relate to one another

not via the belief-systems or identities to which we feel attached, but through concrete practical issues which we care deeply about, we can co-operate and act in concert very effectively. For example, I and a covered friend of mine co-hosted a talk show on one of the alternative TV channels for sixteen months. We discussed various social and political issues, as well as different manifestations of discrimination. She and I became very close friends too and started to share our respective social spheres with one another. Thus for example, when we went to places frequented by more secular people in my neighbourhood, I realised how people stared at her head-scarf disapprovingly. Or conversely when we went to places frequented by more religious people in her neighbourhood, this time it was the way I dressed that attracted the disapproving gazes of people. But I think there are still too few people who enjoy heterogeneous experiences like this. It is true that now there is a certain measure of heterogeneity within the society. It is quite possible, for example, that in one single family, one member is covered and the other is not. But when it comes to taking collective political action, to acting in concert in the public sphere, the different neighbourhoods are still segregated, and political debates are still very polarised and tense, which I hope will be overcome in time.

What actual debates exist on the relation between religious institutions and the state, and what is their historical background?

In Turkey, religion is a subject that dominates both the public sphere and public debates. In fact, in Anatolia, religious belief has always been controlled by political power – this was the case not only in the Ottoman, but also in Roman and even earlier, periods. In the transition from the Ottoman Empire to the Republican regime, the Caliphate was abolished but, in its stead, a new institution was established: the Diyanet (Presidency of Religious Affairs), which is essentially a mechanism through which political power or the state can control religion. It was established to discipline the religious activities particularly of the Muslim population. From the establishment of the Republic to this day, the Diyanet is the only legally sanctioned institution of faith for Muslims.

In the process of the nation-state building in Turkey, Sunni Halafi belief complemented the Turkish ethnic identity as one of the fundamental building blocks. Those who were not Turkish or Sunni were categorised as “others”. Thus Armenians, Greeks and

Jews were relegated to a minority status and treated as second-class citizens. Other belief groups, like the Alevis, Assyrians and Baha'is, were undefined from the very beginning and therefore they could neither enjoy minority rights nor benefit from the Diyanet's services. Alevism involves a significant degree of internal diversity and plurality, but it was reduced to its relationship with Islam and disregarded as a separate faith.

Since the nation-state building process had not only a religious dimension, but an ethnic one as well, the Kurds were subjected to Turkification policies on the basis of the religious common-ground that they share with the Sunni Turks. Religion played an important role in the process of nation-building and this is reflected in the fact that political arguments are usually couched in religious terms and Friday Sermons often echo the political arguments of the day.

After AKP's (Adalet ve Kalkınma Partisi, *Justice and Development Party*) coming to power in 2002, the scope of activities of the Diyanet has been expanded to include the issues of women, family, and foreign relations. Thus there is an obligatory religion course in high schools; however, this is not a "religious culture" course covering all belief or non-belief systems in a balanced way. No, the curriculum of the obligatory religion course is based on Sunni Islam. Students from other faiths – except established minorities – are required to take these courses. There are elective religion courses as well, which in fact are required courses, because in most schools alternative courses like philosophy or human rights are not offered, and students are directed to take religion courses as "required electives". So while education is expected to gain its independence from religion, religion and education have become more and more entangled with one another. For example, in the University Entrance Exams, philosophy questions were replaced with religion questions.

There is also the head-scarf issue. Admittedly AKP could not have solved the issue in the early days when it first came to power because, at that time, deeply entrenched reflexes of the state would not have permitted it. But AKP could still have solved the issue much earlier than it did. AKP waited for almost ten long years in which head-scarfed women were prevented from starting their professional careers; very few of them managed to continue their

education, only those who were well-off could go to foreign countries for an education. In this context AKP saw the head-scarfed women as a rich source of votes: as long as the issue lasted, they could get the votes of the head-scarfed women by promising a solution. So there was a reason for postponing a solution.

Groups which are classified in the official discourses as “non-Muslim minorities”, like the Armenian and Jewish communities, also have problems of discrimination. The dominant group still seeks to marginalise and exclude not only them but others also. For example, the Halki Orthodox Seminary which was forced to close in 1971 is not still not reopened.

Do you regard religion as a source of inspiration or an obstacle for Green politics, and how?

I think the formulation of this question is problematic. Whether we see religion as an obstacle or inspiration does not matter, religion is a sociological fact which is already out there and I think the real question we should ask is: what sort of a relationship should we establish with belief, religion, or with faith in general. In Europe, or in more secular contexts, this relationship can be based on recognising the rights of certain belief groups, but in Turkey the rights of the non-believers too must be taken into account, because there is a serious marginalisation of the non-believers going on here. To my mind, the real source of inspiration should be the liberties. We need to establish the spaces of freedom where all differences can peacefully co-exist with one another.

What conflicts are there between fundamental rights, like the freedom of religion and the principle of sexual and gender equality? Should Greens tolerate views which are intolerant of equality and emancipation?

Some religious people claim it is their freedom of expression to say that, according to Islam, homosexuality is a sin. Yet whenever this issue is discussed, and I remember moderating a discussion on this very topic, we always reach a point where, in the Turkish context, LGBT individuals are regularly subjected to violent attacks and murdered, and expressing this opinion in the public sphere would just add fuel to the flame. Yes, it may be true that Islam sees homosexuality as a sin but, in an environment where violence against LGBT individuals is the rule rather than the exception, this opinion simply encourages and directs some people to kill

other people. So can we regard the expression of this opinion as a freedom? If we can provide a transparent and fair environment, different opinions can obviously engage in a discussion with one another. But if the lives and the livelihood of some people are under constant threat, this would pose a greater problem. So should there be a restriction on the freedom of expression? Such restrictions are problematic also.

So you think that words are not innocent?

Yes, words are not innocent, but banning them is not a solution either. What we need to do is to strengthen the spaces of freedom in society and encourage people to use those spaces to get to know each other. The conclusion I reached, after conducting a number of workshops on the subject, is this: a devoutly religious person can very easily come to the point in which she says “I will not express this opinion in the public sphere any more, because causing someone’s death is a greater sin”.

Gay Pride is celebrated every year in June and, in Turkey, it has been for the last ten years. First it was a very small group of people, but now the celebrations are big, festive events. Last year Gay Pride coincided with Ramadan and AKP has reached such a point that it staged an obstruction of the sort which would not have been possible for it to do so in 2002. They said that such “immoral acts” are not acceptable, particularly on the holy days of Ramadan. Such things should not happen. Let me repeat what I said before: in the past it was the religious people who could not enjoy their freedoms; it was they who were mistreated. Now that a political party with Islamic ideas is in power, it is they who mistreat others. None of these accord with democratic and pluralistic values.

Similarly when we look at the murdered women in Turkey, we see that the patriarchal and the religious are intermingled. Much is justified on basis of religion and religious sin, yet it is the patriarchal culture that manifests itself. And we should emphasise that day after day the number of murdered women in Turkey increases. I think this is a consequence of the same environment of inequality. We already talked about the unequal treatment of the citizens holding different religious beliefs. Here we are talking about gender and sexual orientation based inequalities and even about the ease with which women and LGBT individuals are killed.

How do you see the place of Islam in Europe?

We criticise Turkey, but is Europe really secular, I wonder? Of course we are talking about a continent where the very concept of secularism came into being, but there are countries where all holidays are Christian and the holy days of other religions are not established. We take Europe as a reference point, but Europe, for its part, takes Christian references. We should question the relationship that Europe establishes with religious belief. In this context, while all the figures or symbols of Christianity are easily accepted as the norm, the symbols of Islam or other religions get inevitably excluded. One of the reasons for this is a historical phobia fed by entrenched prejudices – the fear of Sharia, barbarism, regarding all forms of religious covering as reactionary. I mention this in relation to Europe, but it holds true for the secular section of Turkish society as well.

There is a Europe which is very well aware of this exclusion, of this marginalisation, and seeks to fight against it, a Europe which recognised the political liberties of Muslims well before Turkey did. There is however another Europe which seeks to tame them, which reluctantly endures them only as long as they “behave” themselves by not getting too visible in the public sphere or by not demanding too many rights from the mainstream. Thus for example, there was a case in which religious symbols regarding Islam were banned in France. I remember that it was young people of Algerian origin who reacted to that ban. When it comes to banning or giving freedom to religious symbols, there seems to be a double standard. But still, were certain freedoms given? Yes. Is it easier for head-scarved women to find employment in Europe than in Turkey? Yes. But can they get promotions? Are they exempt from prejudices? Perhaps not. And this is not something related to religion only. It has something to do with the more general problems of being an immigrant, being an “other” in European societies. I think the fundamental problem is the orientalist perspective; the prejudice that European societies cannot live with a different culture; thinking of western knowledge as the hegemonic norm; and the marginalisation and exclusion of the other that results from this perspective. I think this is the fundamental problem. There are obviously cultural differences, but I do not think these are insurmountable differences. It has something to do with understanding the other.

What upcoming challenges are there in the relation between religion and society, and how could Greens respond to those challenges?

When we look in the Turkish context, it was the more religious people who were victimised before, but now the followers of political Islam (and I should emphasise that I do not regard the followers of political Islam and religious people necessarily as identical groups) who are in power. And it is now they who exclude and marginalise others who are different, those who are critical of their policies. Ultimately this is a problem of power.

In addition there is the problem of violence associated with ISIS which we experience and observe, not only in Turkey but also in world politics. There are some who defend ISIS as a justifiable reaction and rebellion against all that is associated with western orientalism. But nothing that can justify the violent acts of ISIS's – killing innocent civilians, enslaving women, etc. Their violent methods are inhuman and barbaric.

What ISIS is and is not needs careful understanding but in general structures like ISIS are fed by Islamophobia. Let me clarify a little: it is important to research and criticise the structures that support ISIS but, unless we also study and understand how such structures come into being, our analysis would remain incomplete. Whatever the sources of ISIS are, in Europe and Turkey people sense an attraction to it. And in the attraction of ISIS for these people, the sort of Orientalist Islamophobia that is prevalent in Europe plays a role. In Turkey also, the restrictions on the freedoms of religious people that were once prevalent led them to feel oppressed. The feeling of being excluded from the mainstream of society, led them to identify themselves with a structure like ISIS which is heavily loaded with Islamic references.

What I think Green politics should do is to view all belief – and of course non-belief – from the perspective of liberties and adopt an issue-based, rather than an identity-based, approach to the relationship between human beings and nature. At that point all the bans, injustices, and discriminations we experience today can be revealed for what they are: namely, as problems that can be overcome through a struggle for equal liberties for all. And this, I believe, is the common denominator of all identities.







Mary White:

I am a small part of the great sea of life



Mary White (born 1948) is a former Green Party Member of the Irish Parliament for Carlow/Kilkenny and former Minister of State for Equality, Human Rights and Integration. She is a walking guide, forager, and flora and fauna specialist and runs Blackstairs Ecotrails in the Blackstairs Mountains in County Carlow with her husband Robert and their daughter Dorothy-Ellen. Mary White works with schools and organisations running wildlife and foraging workshops, as well as fun trails for children and adults. Since the 1980s she has been recording birds, butterflies and fungi in the Blackstairs Mountains and the Barrow river valley, and has tracked changes in local biodiversity due to agricultural practices and climate change.

What does religion mean to you?

If I think carefully about what religion means to me, I think of growing up in an Ireland that was moulded by religion. Every aspect of life, politics, sport, business and education was impacted by it. There was a sense of fear, of being under pressure to behave in the correct way – that was what religion meant to me in the past. However now when I reflect on the mystery of life, the sacredness of life, what I call religion is in the magnificence of the creation of life and the beauty and terror of the natural world.

I was brought up in a conventional Catholic family. My parents were liberal but we went to all the religious ceremonies when I was young. What religion is to me now, is not what it was growing up in

County Wicklow. I have had a good think about what it means to me – I am not anymore a conventional Catholic in a strict sense, though I go to Mass and I read in church, and help out in the parish locally. But I find as I get older I am thinking more widely, more deeply and more outside of traditional church dogma. I am quite happy in my own head about my religion which is verging on the pantheistic in the sense that the environment and how we treat our world matters deeply to me rather than a formal belief.

Religion, outside of my own meaning of it, is often the glue that keeps communities together – the ritual, the weekly gathering, the sense of community, the sense of belonging, even if that faith is not as strong as some would like to have it. Religion is not a building, it's not a place; it is people searching for meaning in the world. Often that search is fruitless, but sometimes the clouds part and there is a peaceful illumination of ideas, thoughts and beliefs, which is what I experience as natural grace.

My own personal religious belief has been an inspiration to me in public life. When the chips were down and the Green Party deputies had huge pressures when in government during the economic collapse between 2008 and 2010, walking out of Leinster House (the seat of the Irish Parliament) and up into the mountains or along a beach listening to the crash of the waves, I found great peace. There was such peace in being up high, being away from people and away from stress. When having political difficulties walking for me cleared my head; after walking I knew what to do and was not looking over my shoulder at what others thought. I took to the mountains or the sea to resolve my problems. I found great solace walking at night in the long evening light between dusk and nightfall, I would walk with my husband Robert, often for hours in silence, and at the end I would know what to do and how I was going to vote and I would be at peace with it all.

I once read about what is in a teaspoon of soil, and when you are walking along for a couple of miles you are walking on literally millions of fungi and billions of bacteria and protozoa. I would feel the earth and the soil underfoot giving back to me this incredible life that is going on under my feet as I walked along, the living world, I found it very energising to think that I was walking on this living soil full of living creatures. I would find it soothed me with the

sense that my problems were irrelevant compared to the power of the life force in the soil. It was a wonderfully energising walking at night in the hills looking down on the city and simply putting one foot in front of the other.

It sounds like a very powerful experience of being alive, and that everything else falls into perspective when we have that direct experience of being and primal aliveness

Yes, it was a primal experience of feeling and hearing my own beating heart in the dark and knowing I was a small part of the great sea of life. I agree with Emerson that enlightenment was more possible in a forest than a cathedral and that the preservation of wilderness was essential to creativity. There has always been a tug between orthodox churches and thinkers such as Emerson and Thoreau arguing, as Emerson said, that “revelation was possible through nature”. I side with Emerson on that one.

There has been a return to earth centred concern in religion. This is sometimes viewed as pantheism, but most people do not care about the labels traditional religions give to this core relational idea. I feel much freer as I get older from the traditional mould, I am thinking more outside the box. As I get older I have become more radical rather than more conservative, as often happens. I feel like a migrating butterfly venturing across the ocean getting stronger and freer in my mind.

Do you see a difference between religion and spirituality?

I do feel there is a distinct difference between religion and spirituality. I find that formal religion has become less important to me but I am deeply aware of that spiritual part of my life. I find immense solace in sitting in huge Gothic cathedrals, thinking of the faith of generations of worshippers who came to these magnificent buildings, who found solace within those ancient walls and were moved by the incredible beauty of sacred music. I feel moved by that myself. It was probably what induced me to study the great Gothic cathedrals of Western Europe while at Trinity College.

I think that there is a huge divide between institutional religion and personal spiritual experience. It seems that people want the church for the most important parts of their lives, baptisms, christenings, weddings and burials. No matter how secular Ireland is becoming, there is still that pull towards religious celebration

at these pivotal times of life. So what does that say about us? Are we being hypocritical? Are we linking in to our local church so that our children will belong when they first go to school? Or is there a residual longing to belong to a wider community despite the secularisation and individualisation of Ireland and the times that we're living through? Perhaps we need some teaching about practical spirituality that the churches do not at present provide, such as how to pray and meditate for example.

Has religion been an inspiration or a hindrance to you in Green activism?

Possibly a hindrance. I have always believed in the separation of church and state, so for that reason I believe religion was a hindrance in Green activism. Many public debates in Ireland, such as that on the abortion issue, euthanasia, the switching off of medical support for people in a persistent vegetative state, have been dogged by rigid religious belief. The state should govern and legislate for all the people not only religious minorities. Having said that, when canvassing and looking for support as a Green candidate, immensely personal issues came up on the doorstep and people wanted to know where I stood on these contentious issues and in a rural, conservative constituency my answers were not always what they wanted to hear. However I ignored the pressure to conform to Catholic doctrine on these matters.

Traditional religion in Ireland was full of petty rules and fear based compliance. I remember the nonsense over the Lenten fast, there was an aura of fear about breaking the rules. A little fasting is good for the body, but I think that as a nation we came to have a dislike of fish because we were forced to eat fish on Friday because we could not eat meat and be a good Catholic. I went to Trinity College Dublin and at that time there was a ban on Catholics attending the Protestant University, therefore you had to get permission from the archbishop to attend Trinity, if you were Catholic. My father thought this was nonsense, and he said "I am not going to any archbishop, the ban will go sometime and you won't all go to hell for attending Trinity". And so my brothers and I all went to Trinity without asking the archbishop. When you recall it nowadays it seems utterly bizarre. It came from an era in which the church expected total obedience, but that is now long past.

Religion has been very present in Irish public life in a very explicit way. How has that affected your own political and public life?

We have experience on this Island of two states which have been dominated by religious faith; Catholic Ireland in the republic and a Protestant state in Northern Ireland. It has been a relief to see the development of the separation of church and state. In the past this conformity to church doctrine led to so much personal pain for many people.

However it did not really affect me personally because I ignored it. When I was a councillor and member of parliament and active in politics, religion was almost irrelevant in that it didn't affect my politics at all except when issues of the anti-abortion amendment to the Irish Constitution or euthanasia or such issues of conscience came up. There was always a prayer before we started proceedings in the Council Chamber and in the Dáil Chamber (the National Parliament) which I thought unnecessary but I could see the symbolism of what it meant to others.

Religion has affected our public space and growing up, it was totally in your face, religion was all pervasive and, while it's a much weakened force, I think there should be greater separation of church and state in Ireland. Of course there is a formal separation in the Constitution, however the state still has a good way to go to remove religion from public life, for example in the schools and hospitals. This is because during the foundation of the Irish state in the 1920s the churches built, owned and ran many schools and hospitals and the new state was dependant on the churches for these essential services, which of course is very different to the experience of other European states. Therefore there are issues in relation to hospitals and hospital care, regarding abortion and women's health and end of life care, which in Catholic hospitals have to conform to the Catholic ethos. However both hospitals and schools are now staffed and run by the state and paid for by our taxes, but the ownership of the buildings is still in many cases vested in the religious orders, these hospitals are controlled by Boards of Management which remain dominated by the religious orders who founded them. The situation is ambiguous in practice as to how end of life care and care during a life threatening pregnancy is to be effected legally and properly in the Irish health system, and it is a nightmare for doctors. I remain a member of the Catholic church and I know am

not being disrespectful to the church when I say it is essential to see a clearer separation of powers because, as a former legislator, I see it as absolutely necessary for legal clarity for both patients and health care workers, so that we do not end up in the Supreme Court again and again over an individual case.

However the state is not something separate from the people who inhabit it so these changes are also personal changes, changes in people. The people are sovereign under the Irish Constitution, and it is because of the 8th amendment to the Constitution (the anti-abortion amendment) which was carried in 1983 that these difficulties arise, and can only be addressed by a referendum of the people, not by legislation in Parliament. Another example is the recent referendum to the Constitution on gay marriage, which passed with a landslide vote. The personal stories of families were immensely influential in passing the referendum. For example I had a friend in a lesbian partnership who died, leaving behind her partner and a little baby. Although they were in a civil partnership she had no rights to guardianship of the child which they had both been raising. The mother of my friend went on TV and spoke of her anguish of her daughter's death and how she wanted to support the Marriage Referendum. These personal stories so moved people – of parents supporting their children for a fairer and more equal Ireland. The referendum was not won by the political class but by those personal stories, not the political voice but the personal stories of families, because Ireland remains a strongly familial society. As a former Minister for Equality, Human Rights and Integration, for me it was a great day and a significant opening up to diversity of our country.

In Ireland we do have a formal separation of powers under the Constitution, however people imbued with a particular religious belief want to see laws which reflect their religious ethos in their Constitution, and this has created a great many difficulties in practice, particularly as we become a more diverse society. As Ireland transformed itself from a pre-modern to a post-modern society with great rapidity, these issues emerged in public debate because of the way they affected people's lives, and they are debated with great intensity. I think this is a good thing – we do not impose laws on people on these issues, we arrive at them through intense debate, brought about by painful experiences. The church has

seemed to focus intently on sexuality in a negative way, and people react against this and forget that that Catholic social teaching has also been very positive in Irish society, tempering capitalism and consumerism in a benign way and providing great examples of practical charity and care.

-





Trevor Sargent:

Practice what you preach



Trevor Sargent (born 1960) was a Comhaontas Glas/Green Party member of the Irish parliament for Dublin North 1992-2011, Green Party Leader 2001-2007, and Minister for Food and Horticulture 2007-2010. He was, before full-time politics, a Green Party County Councillor and a school principal in Balbriggan, North County Dublin. In 2013, Trevor and his wife Aine moved to Wexford where they are developing an organic horticulture business. Trevor is the author of a popular book “Trevor’s Kitchen Garden, A Week-By-Week Guide to Growing Your Own Food” and he blogs about gardening. He is also studying for a Masters in Theology degree from Trinity College Dublin, with a view to ordination as a Church of Ireland (Anglican) priest.

How would you define religion?

Religion to me is having values based on a belief that there is something beyond this life and its day-to-day concerns and general busyness. It is the belief that there can be a special miraculous dimension to life.

What religious tradition do you come from and what does it mean to you and your public and personal life?

I am a member of the Church of Ireland which is part of the Anglican Communion and I have always been involved with my church. The public and personal are for me very much connected and religion has been important for me from a very early age. There are many serious challenges in life, things that need to be done

to bring justice and right wrongs and so on, and those challenges are increasing. Jesus is a sign of hope which is central to my faith and that can be drawn on in my public and personal life. If we remember the letter of James in the Bible, James says that we must not only hear the word but do the work and be active. Faith without action is empty; unless one puts into practice what one preaches then there is no real faith or belief, because it is not acted upon. I feel that when Jesus talked about 'thy kingdom come' he wasn't talking about a remote location, his meaning was that his purpose was to redeem the world and to do this we need to put his words into practice.

My religion motivates me and gives me the strength to tackle intractable difficulties. If one reads the New Testament in the context of climate change it helps; when Christ talks about His burden being light I think it is about sharing what's on your mind and then handing over to Him. You feel you are part of a team and you need to play your part but there are others there. It is like being in a beehive, there are many other bees in the colony, the hive has its intelligent collective decision making process and you can do your bit rather than organising the whole colony yourself.

How do your values and religious belief relate to being active as a Green politician?

I disagree with a certain view that totally separates religion and politics. I don't think you can pigeonhole religion as if it was some Sunday only exercise although I understand this where religion is seen as divisive, but I try to stand where Jesus would stand. I can't see Christ signing up to the way religion has been today presented and I think we should try to recover the humble, tolerant and inclusive essence of Christian faith. Greens often aspire to treading lightly on the earth. If we could all tread a little more like Christ, much of the stress on the ecosystem could be alleviated before too long. In the book of Romans, chapter 8, verse 19, I think, Paul talks about creation waiting in eager anticipation for Green minded Christians to redeem it. Paul does not say those words exactly, but that is how I read it. This redemption includes ALL creation, all biodiversity including humanity, as far as I can understand from reading it in context many times.

Perhaps we need to make the distinction between religion and politics, which may be faith based or inspired by belief, and religion and the state, which is required to be a neutral space between contending beliefs and no belief.

Yes I agree, it is perhaps best to avoid mischievous interpretation of what I mean, which is in no sense intolerant of other faiths and beliefs.

What is your personal experience with religion in public life and public debate?

I was conscious that, as leader of the Green Party, I was there for all members and that meant a large diversity of cultural and religious backgrounds. There was an onus on me to represent a consensus view as the leader and in a collegiate way. That is my natural style anyway, so I was not very public about my religious faith, although it wasn't a secret either. There were people in the Party who were not comfortable with religion straying into politics. I was happy to talk about it if asked, but I did not want to initiate discussion about my own personal faith. I did take some comfort in the manifesto of the Green Party of England and Wales which had a policy on the spiritual dimension to life and which recognised this as important part of life which wasn't to be ignored and couldn't just be set aside as an irrelevance in political discourse. I was also comfortable in the openness of the Green movement to a wider circle of ethics to include respect for other animals and creation generally.

As a member of parliament I found my faith reached across political barriers and helped with the resolution of conflict, not only with other politicians here in the Republic of Ireland but in Northern Ireland and Westminster also as well as in South Africa and America. I was involved in forming a prayer group in the Irish parliament and this engendered great empathy from people who had different Christian beliefs and different political ideas. It acted as a safe space; it served to break down division.

I recall that in 1996, I was asked to go to Drumcree (In Northern Ireland) as an observer during the orange marching period. (The unionist tradition in Northern Ireland idolises William of Orange, the Dutch protestant who deposed the Catholic King James as King of England at the battle of the Boyne in 1690 and these

‘Orangemen’ march to commemorate the event every 12th July. Some marches go through Catholic residential areas which can be extremely intimidating for the residents and it can lead to conflict and violence). It was a time of tension for the nationalist community living on the Garvaghy Road below Drumcree church which was a focus for the Orangemen who had decided to stay at Drumcree until they would be allowed to march back down the Garvahy Rd. The parades commission had decided rightly that there would be no marches other than with the consent of the residents. However this was not what happened and the march took place without the agreement of residents, and there were riots.

I was a guest of the nationalist community in their enclave. After the stand-off on the Sunday morning the sun came up and I told them that, coming from a Church of Ireland background, I would usually have gone to my local church which that morning was Drumcree church on the hill that was the focus of the conflict. After praying about it, I decided I should attend the church service. This meant getting across barricades and going through security check points, and being dismissed as an idiot for wanting to walk up that lonely road but it felt like the right thing to do.

Were you welcome when you got there?

Reverend John Pickering greeted me and was understandably nervous because of the tension and I asked him where I should sit because I didn’t fit into the Orange and Unionist tradition. Nearby were the seats for the Women’s Coalition and I felt I would be OK with them as they were non-partisan. However, they were not able to get there because of the barriers, so it was a men only congregation of stony faces which filled the church and they began singing the hymn which starts with the line ‘Will Your Anchor Hold in the Storms of Life’, but I was not used to that hymn being sung in such trenchant terms. It was a very surreal moment.

What do you consider to be the main challenges we face as a society in the relation between religion and the state or religion and secular world?

I think that this idea that there should be a gulf of separation between religion and politics needs to be challenged for two main reasons. Firstly, the challenges that we face as a society are large and daunting and in a way disempowering to people because they are so great. People say what can I do? What can I do about climate

change and the widening gap between rich and poor? I'm only me and I have to live, and that's the way life is. What can I do about all the people being killed or made homeless, and other massive challenges?

Unless there is a willingness to harness the power of faith to help people to transcend their particular day-to-day experience and to work and be motivated to do things that are more than humanly possible, then we will wallow in a culture of cynicism and self-pity, and politics will be worse for it. Unless we embrace the potential of reconciling the religions of peace then I don't see much hope and that's why I would be marrying politics and faith in God in my own personal life. I'm talking about marrying both politics and religion to try and help me to be encouraged and strengthened and transformational my own life and hopefully for others also. I think religion has a role to play in helping people to rise to overcome overwhelming challenges.

Secondly, because religion has been effectively told to stand in the corner and mind its own business and not interfere with politics, it has become completely fixated with matters of personal sexual morality and it has begun to cannibalise itself. It is so fixated with these matters that are not part of those great global challenges. For example, population growth worldwide is causing an enormous ecological footprint and making it more difficult for that very population to sustain itself and for the next generation to have a sustainable life, and yet the religious discourse seems to be locked in a time warp of 'go forth and multiply'.

How do you see the place of Islam in Europe?

It will be difficult to reclaim the message of peace that is central to all of the faith communities that Abraham has been a father figure for, Judaism, Christianity and Islam. Much will depend on people who are accepted within the different faith communities coming together and identifying what unites them, because the focus seems to be on what divides them. This is my own view but one based on reading and faith and prayer.

I think the conflict with Islam has little to do with religion. People who are carrying out such attacks as the atrocities in Paris, London, New York and other places are endangering people of all faiths and none, and encouraging reactionary Europeans to regard

people of the Muslim faith with suspicion. The hijacking of religion is something which people will need to challenge, given that it is causing such divisions and such pain. I think of the 165,000 Christians who were killed last year because of their faith, I would say most of them were killed by people who didn't know what Christian faith really stood for, other than perhaps it was shorthand for western colonialism and they would identify Christianity with that. People of Christian faith need to speak up for what Christianity is really about. Mahatma Ghandi famously said, when asked his view of Christianity in Europe, that he thought it would be a very good idea.

-



John Barry:

What are the stories we are telling ourselves?



John Barry (born 1966) is Professor of Green Political Economy at the School of Politics, International Studies and Philosophy in Queen's University Belfast. His areas of research include Green political economy, Green economics, and theories and practices of reconciliation in Northern Ireland. Barry is a founding member of two think tanks, the Centre for Progressive Economics and Greenhouse, and is also a founding member of Hollywood Transition Town. He is a keen cyclist, indifferent cook, frequently absent from his family and a passionate believer in the ability of people to initiate social transformation. A former leader of the Northern Ireland Green Party, he is a Green Party Councillor in Ards and North Down Borough Council.

How would you define religion?

I want to begin by differentiating religion from spirituality. Religion is the institutionalisation of transcendence, whereas spirituality is self organising like ecology. I would define spirituality as the human connection with the larger whole, including other people, our ancestors, animals, trees, plants and the universe. Myself, I am a lapsed Catholic. Green ideas for me are a replacement for a Catholicism I didn't connect with, though I appreciated the social justice aspect of Catholicism. I was influenced by Alastair McIntosh's book *Soil and Soul: People versus Corporate Power* (Aurum Press, 2001, 2004) which combines ecology, social justice and radical spirituality. It starts with a vivid account of his childhood

on the Hebridean island of Lewis whose local economy, spirituality and culture were beginning to unravel with the advent of modernity. It can also be read as a book of theology in which Calvinism and eco-feminism are fused to offer a liberation theology of creation.

For me, poetry is a portal to spirituality and is the heart of spirituality, expressed for me in the earthy mysticism of Irish poets such as Patrick *Kavanagh* (1904-1967) and Seamus Heaney (1939-2013). Poets are well regarded in everyday life here in Ireland, which is not the case everywhere. John Moriarty, the poet and philosopher, is a wonderful mystic in the Irish tradition. He is easy to listen to but hard to read, as is also the case with James Joyce. I think you need to listen to Joyce's *Ulysses* and not try to read it, because it springs from the oral tradition. I think this poetic reading of spirituality enables me to reconcile my own humanism with those who have a God-centred sense of the meaning of life and so on. It also differentiates my atheism and humanism from those fellow humanists who condemn religion and spirituality outright.

Part of the reason for the tenacity and resilience of religion and God-based spirituality is their long historical experience of perfecting this poetic and imaginative articulation of meaning. The aesthetic beauty of religious expression cannot be denied – whether it's the beauty of Islamic architecture, or Gregorian chants, or Native American dance and religious rituals, or the beehive huts and the story of those monks who built them on Skellig Michael off the Kerry coast. This is what I mean by the poetry of religion and spirituality, the way it weaves an aesthetically pleasing narrative about the human condition, its tropes and use of standard narrative devices – failure, being lost, loss, enlightenment, redemption and so on. The poetry is also expressed in terms of the rituals and narratives that most religions and spiritual traditions create around some of the threshold events in human life – birth, death, marriage, collective food eating, for example.

Why do we make a distinction between religion and other transcendental values and beliefs?

We have bifurcated our value system. There is dignity, power and poetry in equality and democracy and I would give it the same significance as religious belief. The great monotheistic religions, such as Christianity and Islam, arrive at a particular moment when

we move from simpler societies to land-based and farming-based societies and cultures. Christianity has the idea of stewardship, the earth is not made for us to exploit, which is a capitalist view; we were made for the earth and to pass it on carefully to the next generation. Greens can find common ground with the religious belief in stewardship because Greens also stand for stewardship. Christian or Muslim or Jewish or Hindu or Buddhist, we believe in taking care of God's creation.

You are a Marxist yourself. Would you call Marxism a religion?

Yes, I think Marxism is a great Christian heresy. It has all the hallmarks of a religion: the holy book; the secular saints; the story of the fall; redemption and the future utopia, it has all the archetypal themes. It is the story of a pre-fall, pre-lapsarian idyll; then the fall into capitalism; redemption and catharsis through workers' revolution and the promised utopia in terms of heaven on earth. It has all the traits of the Christian myth, including its own Jewish prophet.

I was always uncomfortable with versions of Marxism, such as the Socialist Workers Party and the Communist Party, which simply dismissed religion as the opium of the people. The view was that a religious disposition was a sign of idiocy. Of course, a pre-modern religion can be used for conservative non-progressive purposes, yet the impulse behind religion or spirituality is positive, religion contains the passionate and progressive nature of the spirit. There many areas where a Marxist view and a Christian one are identical. The Brazilian Catholic Archbishop Dom Hélder Câmara (1909-1999) said "When I give food to the poor, they call me a saint; when I ask why the poor are hungry, they call me a communist".

I am an unashamed Marxist in that I understand the world as structured by economic forces, but I am also a humanist in that I understand the importance of a non-material dimension of life, and religion cannot always be reduced to an ideology or false consciousness or the balm of a difficult life. Marx's view of religion is that it was the cry of the heart in a heartless world. Comfort, yes there is an element of that, but also an impulse towards something bigger than ourselves. This is itself what Marxism is about and Marxism is insufficiently critical of its own ethical dimensions; it tried to assert that it is not an ethical philosophy, that it is scientific, it fell into the trap of 19th century scientism. In fact we are really talking

about justice and injustice, but these were seen as bourgeois ethical ideas. For me, however, what gives Marxism its righteous indignation is the religious and ethical dimension. The righteous indignation which fuelled Marxism also I think fuels a lot of Green activism, which is fuelled by the knowledge that the world is marred by suffering, by injustice, by vulnerability, which can be solved so that suffering is unnecessary suffering. In my academic work I am upfront that my view of the good life of human flourishing is one which weaves suffering and death into it. I disagree with the naive view that we can produce a gross national happiness – I am all for well-being, but a fully flourishing human life is one in which we have stories of suffering and death.

The creation of a new life, religion gives us the rituals of passage, marriage, birth, death which give a sense of meaning. I was married in the Catholic church partly because it was what I was familiar with. You can divest religion of the theology of an off-world male deity and the rituals still have meaning, they are familiar stories and I think this is what religion brings to people's lives – the familiar stories and narratives. We are losing a sense of having a good death in Ireland; that was a blessing, to wish someone a good death that was part of what religion could bestow, a good death, at peace with your demons and your conscience. Religion is an element of our experience of liminal areas of our lives, of birth and death.

Do you regard religion as a source of obstacle or inspiration for the Green movement?

The question we must address as Greens is what our stories are, what are the stories we are telling ourselves about the current crisis? I do see a role for faith communities in the transition from unsustainability. I think the faith communities have been lacking in involvement in tackling climate change, perhaps because of too narrow a vision.

There is indeed a particular onus on faith communities because, if they really believe this is God's creation, what are they doing to protect it, how can they not criticise consumerism driven by global capitalism and the injustice? The Bible talks more about injustice than homosexuality, so why are people obsessed with these narrow issues, and not tackling the greater issues of injustice and unsustainability in the world?

We have a shared common ground but it is annoying to meet devout Christians who are hyper-materialists; I ask them what would Jesus drive? He would surely ride a bicycle! They are not living by the book, they have lost their way. The current Pope is interesting and the former Anglican Archbishop of Canterbury, Rowan Williams, is an inspirational figure. It is sad to see the energy that religion can mobilise being corralled into narrow issues such as abortion and gay marriage, issues of sexuality. We should concentrate on suffering and poverty. Christianity to me is about suffering and injustice, not gay marriage. Where are you going to put your energy, on gay marriage or childhood poverty?

You work in Northern Ireland, a region seen to be dominated by religious conflict. What is it like for you as an elected Green politician in such a contested public space?

The north of Ireland conflict is not a religious war. Religion is a badge of identity here; there is an ethno-nationalist conflict between two failed state-making projects: the failure of Great Britain to establish a stable presence on the island of Ireland, and a failure of the Irish Republic to attract Northern Unionists to the civic republican project. Therefore there was a fusion of religion and politics in the public sphere. The outcome was two states with religious identities embedded into them where minorities were isolated. The northern nationalist community is culturally Catholic but I think that their religion is largely about identity. However a marked Catholic collectivism is still part of the tapestry of Northern Catholic identity. In the republic it has faded and become consumerism and secularism.

So how do the Green ideas work in a public space dominated by religion?

In the Northern Ireland context of Christian conservatism on all sides, Greens have different values. Greens are pro-marriage equality and pro-choice in the case of abortion and in the right to end one's own life with dignity. Greens stand out as all other parties express conservative Christian belief and we are listened to. Green values are inspiring to people who want an alternative to what they know and we are an important and different voice in the public square.

How do you see the place of Islam in Europe?

I see Islam as part of European identity, it has always been here. Islam is not a new foreign entity but part of our European history, especially in its influence on the development of science during the Renaissance through the transmission of classical manuscripts and Arabic numerals and mathematics, particularly algebra. It is part of the rich tapestry of ethical world monotheism. Most Islamic scholars suggest Islamic fundamentalism is not representative. Extreme forms of Islam such as those promulgated by Saudi Arabia do not represent the majority of Muslims.

The larger question is how we build a multicultural society in which we can have agonistic rather than antagonistic relationships. A developed democracy is a contended one. The challenge for us as European Greens is the creation of a democratic agonism, rather than antagonism, where opponents are in a non-violent struggle using debate, satire, humour and so on, but not antagonism. We must have ways of sublimating violence, verbal violence is better than physical force but there is a threshold between violence and non-violence. You can criticise Islam, you can use satire but not hate speech. We need to treat our differences with respect and contend with each other not as enemies but through debate and plurality of thought. This is how the European Union was created, through turning antagonism into agonism. It is a realisation of Montesquieu's vision of an energetic and robust public square, full of non-violent struggle. In Europe we believe in the rule of law, but laws are not unchanging. Laws change as the culture changes, for example, marriage equality. However there are some religions which want their customs and beliefs to be the law, and to impose them on others; however a democratic state should never tolerate the intolerant. There must be a strict division between church and state, with the state not endorsing any one ideology but allowing religious freedom. All change should be agreed and be non-violent.

•





Judith Sargentini:

Live and let live



Judith Sargentini (born 1974) has been a member of the European Parliament for the Dutch Green Left Party, GroenLinks, since 2009. Prior to that she chaired the GroenLinks group of councillors in Amsterdam City Council. She studied history and was politically active as a student, among other things in the International Student Movement. Previously she worked for various NGOs in the field of international co-operation, particularly on southern Africa.

How were you raised at home in terms of your outlook on life and on religion?

My name isn't Sargentini for nothing; my father is of Italian ancestry, although that's a long time ago. My mother's parents came from a Catholic enclave in the Dutch countryside. I was what you would call raised as an 'Amsterdam Catholic', which means we didn't go to church and didn't do much religion-wise. When I was born my father went to the Registry of Births, where the civil servant said: "you are both Catholic, I see. Shall I register your daughter as Catholic?" My father replied: "Well, I'd rather be spared that!". Then my parents had their names struck from the church's register. But on holidays we went church in, church out. We also had a little nativity scene, so there was a layer of Catholic culture. My father is a primary school teacher and a teetotaler. I'd call him a humanist, although he doesn't call himself that. As a family we were members of Nivon, an association of nature conservationists.

It's not just about a love of nature, but also about taking care of each other and a certain sense of enterprise. My parents have always done a lot of voluntary work, so that's where my left-wing socialist values come from.

Has your background had any consequences when it comes to your stand in political issues on religion?

I think that, with me, it has had the effect that I like to look at pragmatic solutions. In the Amsterdam City Council there was an issue once about swimming as part of the school curriculum. A number of Islamic schools wanted separate swimming lessons for boys and girls. That was more expensive and it became an issue; there were colleagues who were against separate swimming as a matter of principle. The issue was fought with daggers drawn, while I thought: "what's the fuss?". We don't want children to drown. So they have to learn how to swim. Call it Amsterdam-style liberal-Catholic, let's compromise, lads. What's the use if you have a principled debate in the name of emancipation and at the same time you deprive those girls of a chance to learn how to swim? If they don't, they might drown in a city lake in summer.

Let's consider education. Increasingly in the debate there is the tension between freedom of education, the freedom of religion and the ideal of emancipation and equal opportunities.

I have no difficulty with special schools if they're not subsidised with church money in addition to public funding. If you bring them up to the same level financially and make sure the curriculum is up to standard, great. But at the same time you have to say that the standards should be equal for all. Catholic and Protestant schools were taken for granted, and in addition Jenaplan schools, independent schools and so on were accepted. I myself went to a non-religious Montessori school. But when Muslims discovered they could establish their own schools as well, sparks were flying which was not quite fair, although I'm not happy with Islamic schools with young girls wearing a hijab.

We've had disturbances over girls wearing a niqab at teacher training colleges and wanting to do an internship at day nurseries which is part of the curriculum. But I think there is small chance of you studying at a teacher training college and running a class wearing a niqab. Once you're ready to teach, I think you'll take the

next step and decide against wearing a niqab or a burqa. That's my western interpretation of emancipation, and I still think along those lines. A good teacher has a reasonably flexible mind, as they have to deal with children from various backgrounds. And teacher training colleges are emancipatory; they are accessible to lower class youngsters. My father came from a working-class background and went to a teacher training college. That was a typical case of emancipation. That's why I think we're going to see more hijabs in schools, certainly at non-religious schools. And I think the hijab will become ever so frivolous.

To what extent can the state interfere in education? There's the public interest, but we're also saying that the government should not meddle in matters of education because that's the parents' domain.

That's the Dutch view. In France they may think differently. After the struggle for religiously affiliated education in the Netherlands in the 19th and 20th centuries and after women's liberation, a precarious balance arose with Article 23 in the Constitution about the freedom of education as a result. I like it, because you can't always have clear-cut, principled choices. It's a matter of finding consensus and compromising. That's probably my parents' *laissez-faire* Catholicism. Religious beliefs simply play an important part in life, so you'd better find consensus. But I think parents' desire to send their children to distinctly religious schools is slowly disappearing in the Netherlands.

Your view on emancipation is a token of the traditionally left-wing secularisation: religion will eventually become extinct thanks to the modern world. Is that right?

Yes, I think so. I don't mean to say that religion has to become extinct, if it takes the shape of something that fits in our society. An example is Protestant social welfare in Amsterdam and the Wereldhuis (the Worldhouse). They take care of people without papers and who are homeless, right next door to the distinguished Hermitage Museum. Women take important positions there, in terms of pastoral care, and gays can feel at home. There's that feeling of live and let live. I think that, with emancipation progressing, more and more people will find a kind of religion like this. Fine if there are still people who want to do that differently, as long as they let me live my life.

Time for a definition. What do you understand by religion?

It's a lofty idea about some greater good – which I don't think exists – to inspire you on your life's trajectory. But I could easily replace it with humanism or a set of understandings people have agreed on amongst themselves to make living together possible.

So for you religion is first and foremost an idea rather than a practice with rituals and customs?

Indeed. That ritual side is still about the search for certainty in a society in which one feels threatened. In that respect, yes, I hold the old-fashioned socialist notion that, for many people, the practice will wear out when they fare better socially and economically. I don't see individual kinds of religion dying out so quickly, but, yes, those disciplines based on rules about what you may or may not eat and what to cover your head with. I believe they will fade and I hope they will.

Would you want religion to be purely something felt inwardly, without the visible aspects?

That's putting it rather sharply. I don't mind people wearing their yarmulke, a crucifix or a hijab. I like the modern Iranian way the most, still showing of lot of women's hair. The less you see of a woman, the more annoying it is – but I don't think you should forbid it. You can't take away those women's thoughts. Basically, what I'm concerned with is how to get someone out of the peer pressure, allowing him or her to shape their own free choices.

Ultimately, you're concerned with the freedom of the individual?

Yes. I travel a lot to Africa and of course I am aware of the notion of 'I am because we are'. Still, I find it difficult to go along with that because, for those at the bottom of society, things turn out differently.

How do you view the public debate on religion?

Here in the Netherlands we're used to fundamentalist Christians. You may think they are mentally disturbed, but we see them as a kind of harmless prehistoric relic. But then we do see bearded Islamic boys as a problem. So in the end it's about Islam after all. And suddenly we can't distinguish between orthodox-religious or fundamentalist on one hand and dangerous and violent on the

other. If we see a boy with a long beard in a djellaba, we immediately believe that he must be one of those jihadis.

Does that 'we' include the Greens?

The reactions in the Green group in the European Parliament to the attack on *Charlie Hebdo* in January 2015 reminded me of those which followed the murder of Theo van Gogh in 2004. Firstly, extremists would have to be dealt with rigorously, and secondly, the causes would have to be addressed. When we were looking for speakers for a conference on radicalisation, my colleagues came up with 'sweet, friendly Muslims' who would explain that there was nothing wrong with their form of Islam. I was really disappointed. We cancelled the conference, because if we simplify the debate to the level of 'there really are friendly Muslims who not always take their religion seriously' – in fact the great majority – then we're playing along in the game called 'Islam is dangerous'. That's true for the public debate as a whole: we react to extremist violence with a discussion on European Islam and hijabs, giving people a brush-off in the process. And I think that's really sad. What we should ask ourselves is: why do people radicalise? And then you touch upon really serious topics, such as the relationship between extremism, poverty and development.

Do you believe the Greens should not get involved in religion, except in the case of radicalisation and extremism? Should the aim be particularly on social economic aspects?

Yes, but we should accept religion as the motivation of many people to do good. I am not interested in changing religion point-blank, because that will or will not happen as a matter of course, but we have to discuss the excesses. Issues like crucifixes in schools or the building of mosques don't interest me so much. In the public domain, the government has many ways to help or thwart a religion. As for me, let's take into consideration that religion is important for people to organise their lives.

In order to have a sensible debate on radicalisation, don't you need to have more knowledge about religious backgrounds? Do you see any homework for the Greens in this respect?

Maybe it's just that we think we have become so secular, but still all of us carry our little Christian rucksacks with us and have lost the

feeling for religion. Even if you have that feeling, it doesn't mean you understand why those young men become radical. My conclusion is that many Green politicians in their daily lives function in very European- Christian surroundings. There are enough politicians, Green ones too, who are Christian, and who show that in their work as well. No one bothers about that. But we're waiting for the first Muslim woman with a hijab in the European Parliament. In that respect, the Council of a big city is a better place for discussions like these, because there you're very much dealing with an intercultural context.

The question is if the European Parliament is the kind of surroundings that helps people to brush up their knowledge about the foundations of Islam. I don't know. Would it help to brush up your knowledge about the Ten Commandments in order to understand why people attend rigidly orthodox Protestant churches? As a historian, I do see the importance of church history, but I have noticed that extremists often are alike. I myself have to check I can tell the Sunnis from the Shiites, but I understand why young men radicalise. Where there are young men in abundance, in bad economic circumstances, without a perspective, things go wrong.

I don't know where this debate is going to take us. In any case, we cannot react to the terrorist attacks like the ones we've seen in Paris with a debate about European Islam, not in the least if it turns out to be a debate about hijabs. That's not an effective means to counter radicalisation. But anyway, please don't stay on your own little island where you know exactly what's right and what's wrong.





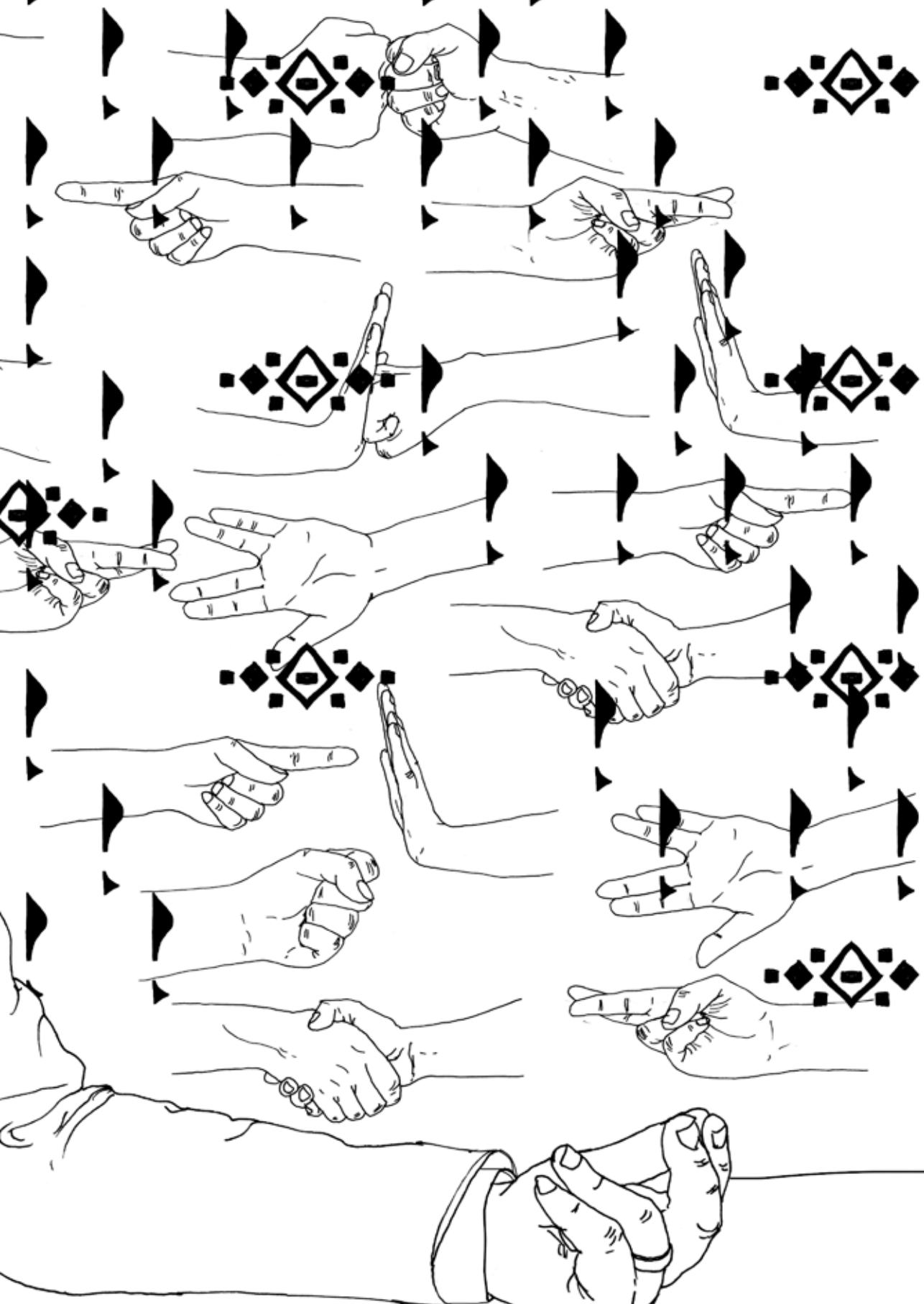

Sergey Lagodinsky:

The Christian idea of religion prevails

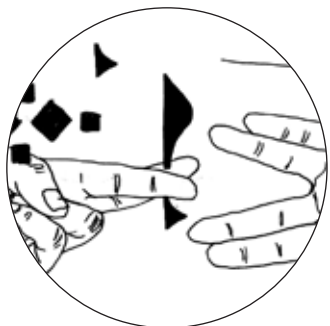

Sergey Lagodinsky (born 1975) is leader of the EU/North America Department of the Heinrich Böll Foundation, the research institute of Bündnis 90/Die Grünen (the German Greens). He read law at the University of Göttingen and studied public administration at Harvard University, receiving his PhD at the Humboldt University in Berlin. He has been a member of the executive of the Jewish Congregation in Berlin since 2008. He regularly appears in the German media and is a commentator for the BBC World Service. In 1998 Sergey Lagodinsky was awarded the Theodor Fontane Prize for his dedication to German-Jewish reconciliation.

What is your religious background?

I grew up in a Jewish family in Russia. Like most Jews in the Soviet Union before 1990, we cherished our Jewish identity, but weren't active religiously. At home we treasured some religious objects belonging to my great-grandfather, the last one in the family to own them and to say his daily prayers and go to synagogue. He was convinced that his faith had saved him during the First World War and the seven-year captivity as a Russian soldier in Austria. My grandfather became a Communist; he rejected the faith and since then any religious identity has ceased to exist in my family.

How would you describe your Jewish identity?

Identity is always hard to define, because it consists of so many different factors. There is a set of experiences from education and

becoming a member of society. For myself, being Jewish means that I'm part of a community, it's a feeling of solidarity. At home the family histories were told. They were about persecution, but also about the pride that the family had achieved so much nevertheless.

In Russia, being Jewish was put on you from the outside. It said 'Jew' on our passports, others were Russian, Tatar or Ukrainian. It was seen as an ethnic origin, within the Jewish community too for that matter. Discrimination and isolation were the normal situation. For us, it was always clear: we are different. I was told at school that I had to be better than the others. Everyone knew there were universities I could never enter as a Jew in any case, and other universities I could enter only if I were twice as good as the others.

When I went to New York on an exchange programme at the age of 16, it was a great shock to discover how natural it was to be Jewish there, and even a secular Jew. In the small town in Russia where I come from, the Jewish community was a small minority. In New York, I ended up in a highly pluralistic community of Jews from all over the world. One of those families organised bar mitzvah for me, American style. They said it would be important for me to go through it; very, very nice. In a religious sense it didn't mean so much to me, but it did make a big impression on me to be able to celebrate your Jewishness. That experience has shaped me.

What happened after the demise of the Soviet Union in 1990?

Owing to the disintegration of the state, one saw that discrimination by public bodies of government was democratised, as it were. Anti-Semitism landed on the street. Anti-Semitic political parties emerged, anti-Semitic newspapers and brochures, calling for pogroms. The anti-Semitism was always lurking in the background; it became more unpredictable than at the time it was in the hands of the state.

Did you yourself experience that?

Well, there were the normal insults, etc. I remember one really frightening event when, in 1993, I came to Moscow with my father to get our visas for Germany. Just at that time, the political crisis was coming to a head. President Boris Yeltsin was diametrically opposed to Parliament, led by Aleksandr Rutskoy. There was shooting, and all kinds of anti-Semitic gangs were walking the streets. And then we both thought at a certain moment: "this is it". We feared for

our lives. One look in our passports and it could be seen we were just about to leave the country. We had to make sure we became invisible, as we were going to be in real danger if someone checked our passports.

Was the anti-Semitism a reason for you to emigrate?

A decision like that always has more than one background. The lack of perspective in Russia played a role, the insecurity about the future. Many friends and relatives were emigrating; that always has a strengthening effect, because you get the feeling you're the only one staying behind. But the anti-Semitism was definitely one of the most important reasons.

Why Germany?

There weren't so many alternatives. It was either Israel or Germany. We decided not to go to Israel because we are... Europeans. What's more, a certain degree of orientalism in the Edward Said sense played a role, a kind of contempt with regard to the East. When we got the opportunity to go to Germany, it was clear to us. Of course we were aware of the history of the Holocaust, but that wasn't a reason not to go.

However, I have noticed that being Jewish in Germany always carries a social aspect with it as well. Non-Jewish Germans project their complexes and images – including the false ones – of Jews on you. So people usually take it for granted that I pray and go to synagogue. If that turns out not to be the case, they say: “but then you're not a Jew”. The assumption that Jewry is something like Christendom with a Star of David stems from a lack of everyday contact with Jewry that has gone on for decades. What exists is a construed image. It's quite a daunting task to deal with that. Many people are offended by the images they're being labelled with and in which they don't recognise themselves. I think that I, with my experiences with discrimination in my youth, can deal with this in a much more relaxed way. I'd rather see it as a certain kind of curiosity, as a voyage of discovery for the majority. Such conversations are tiresome, because you have to begin by disappointing people first: there's something wrong with their image. But these conversations are also interesting and exciting.

You have shaped that social role among other things by becoming a

member of the Jewish Congregation of Berlin. Can you say a bit more about that?

Owing to the sizable immigration of Jews from Russia, or actually predominantly from Ukraine, the Jewish community in Germany has been strongly Russianised. 95% of the Jews in Germany come from the Soviet Union and have emigrated to Germany in the past 25 years. The Jews living here before 1989 were mostly so-called 'displaced persons', from the concentration camps and commonly of Polish origin. There were no German Jews left. When an increasing number of secular Russian Jews were coming, that was the first impulse for this group to say: "you are not real Jews". I have always resisted that publicly: if your mother is Jewish, you're Jewish – that is still the official criterion. We wanted recognition for our other non-religious way of Jewishness. Russian immigration was the onset of the pluralisation of the Jewish community in Germany. Now there are orthodox, liberal and other tendencies within the Jewish congregation. Being Jewish is no longer reduced to being religious. Some visit the synagogue, others aim at cultural activities or make use of the schools and kindergartens falling under the Jewish congregation. Many elderly who don't speak German so well have their own Russian clubs. It gives them some grip on this society, in which they often feel lost. I believe you have to create room for that, because you can't tell the elderly to change and give up their identity.

I am asking the established group for empathy and generosity, and to the Russians I'm saying: "you're the majority now; you have to be tolerant and show openness towards the other groups". You have to have mutual understanding and that is why it's so important we are aware that the Jewish identity is a binding factor. Even secular Jews recognise that eventually it is the Jewish religion that keeps us together. But that foundation is open to interpretation.

Has religious practice not always been crucial for the survival of Jewry?

Yes, that's going to be the big question. We have to accept the existing plurality of Jewry. But the conservation of Jewry – without mentioning the outside stamp – over a number of generations is, of course, strongly linked to education and schooling. Jewish schooling, not only in the religious sense, is the alpha and the omega. By linking the acceptance of several identities, some of

which are non-religious, to attractive learning opportunities for the younger generation, you can look after intergenerational identity.

To what extent does your Jewish identity influence your political outlook?

The experience of belonging to a minority, both as an immigrant and as a Jew, has made me look differently at many things. As a Jew and a politically-minded human being, you somehow do not fit into the clichés of progressive or conservative thinking. You feel uncomfortable all the time. You feel pressure from various corners. On one hand you are against racism and anti-Semitism, on the other you are the object of the racism coming from other minorities, such as Muslim minorities and Russian immigrants in Germany. On one hand you're against coercion by the majority, on the other hand you aren't accepted by some minorities.

In addition to this, there is historically a complicated relationship with the Christian supremacy in culture. For example, concerning politics vis-à-vis Israel it's really awkward. I am critical of much of what is happening in Israel and, within the Jewish community, that leads to a lot of debate. In society at large you have to deal with all kinds of projections and expectations. I have noticed that arguments are often not really heeded and weighed, but your Jewishness is being used. You're always caught somewhere in between. You end up in a highly remarkable mix-up of varying loyalties, convictions, projections and complexes. That makes it very difficult to be a classical Green politician, someone who stands for an unconditional multiculturalism and who rejects out of hand any form of conservatism or anything pointing towards a thinking in terms of community.

Let's take an example of the criticism of circumcision coming from society. How did the Greens deal with that?

Within the Greens the debate reflected the debate in society. The opponents of circumcision appealed to individual rights and the protection of children. They see circumcision as an unjustified and irreversible intervention into people's physical integrity. I can understand that as a lawyer: I see the tensions with other fundamental rights. The question is how do you deal with it? As far as I'm concerned, the answer doesn't lie in the individual freedom of religion, but rather in the rights of parents to raise their children

as they see fit (Article 6 of the German Constitution). That's a clash with the Green idea of the unconditional, atomised right to self-determination from birth. But this does not exist: we are formed by our parents and we have to live with that, Jew or non-Jew. Everybody has to fight that out among themselves and with their parents. This is all the more reason why the debate on circumcision also belongs within the religious communities. Unfortunately, the way the public debate went has made an internal discussion impossible. The reproach – expressed in an ultimatum-like and accusatory tone – that this fundamental religious practice is a crime, has criminalised two large religious communities. In such an atmosphere, you cannot ask difficult questions without raising the suspicion that you take sides with the group criminalising your religious community.

In addition, this debate is also about the acceptance of a pluralistic society and about the relationship between minorities and the majority. Many arguments were Christian, although undoubtedly those using them weren't aware of that. Secular interlocutors said: "why do Jews need circumcision? They can read some circumcision formula instead." Or: "religion isn't about 'physical mutilation', but an inner conviction. Faith resides in the heart." The idea of the circumcision of the heart comes straight from St. Paul (Romans 2:29). This reduces the core of what religion is to what Christians, or people who used to be Christians, understand by religion.

How would you define religion?

In Judaism, religion is first and foremost about ritual. That's why Judaism is called the religion of the law. You practise it in what you do, much more than by what you believe. If you carry anything in your heart at all, it's the torah, the laws. But it's even better to wear the torah visibly on your arm. Judaism is a behavioural religion, not a religion of belief. And many people do not understand that; worse still, they have depicted it as irreligious and wrong, thereby unconsciously Christianising the idea of religion, not doing justice to plurality and tolerance, leaving no space for others, for minorities.

Are you expecting more clashes when it comes to tensions about fundamental rights?

Democracy feeds on these tensions, it's part of the game. I do think they will increase with Muslim immigration. Islam will continuously

keep the relationship between religion and the state on the agenda, thereby making visible that it needs revision. Take for instance the relationship between the state and religious communities and the organisation of church taxes. But we shouldn't abolish a system that functions by and large. I don't see state laicism emerging in Germany. Instead of doing away with the 'privileges' granted to religions, you would do better to extend them to others devoting themselves to society.

Do you see a role for the Greens in the debate about the place of religion in society?

I certainly do. The Greens are offering a model of how to deal with differences. At the same time the secular liberal-democratic discourse within the Greens has the upper hand, as in the rest of society. It is striking, for example, that Christian ways of thinking have less legitimacy in the Green Party, as they are not seen as part of the Green ideology. It seems important to me that more people with a background in migration and members of minorities join the Green Party. To my mind, the Greens can take advantage of their special, intractable position and way of thinking. That includes religious people. The Greens are still dealing with too many taboos in this field. When it comes to refugees for instance, they say: everyone is welcome, full stop. I'd say: everyone is welcome, comma, because in the end all these people will have to learn to live together with each other. This discourse is important for minorities who are faced with distinctly different questions than the majority. It certainly counts for the Jewish minority as it is vulnerable. The Greens must learn to deal with the questions minorities ask.

•

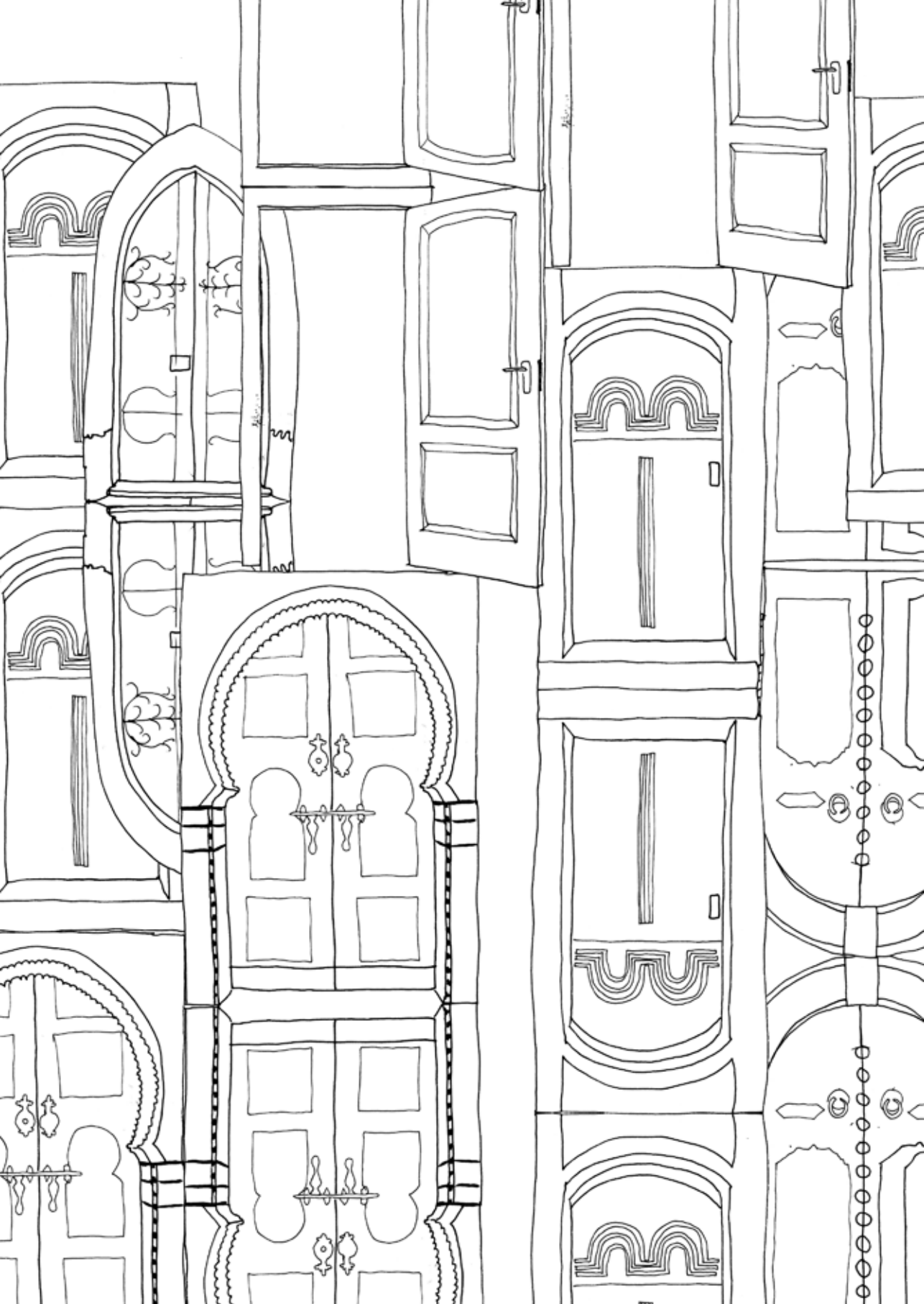



Bettina Jarasch:

Develop a different Green Party culture

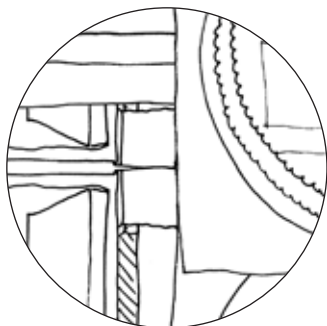

Bettina Jarasch (born 1968) is a member of the Executive Committee of Bündnis 90/Die Grünen (the German Green Party) and Chair of the Berlin Executive Committee. She studied philosophy and political science at the Free University of Berlin, and previously worked as an editor and as advisor to the Green MP in the Bundestag (German Parliament) responsible for religion politics. Bettina Jarasch is the Chair and the Report Author of the Commission on Philosophy of Life, Religious Communities and the State, which was founded by Bündnis 90/Die Grünen in 2013. The results of this Commission will be discussed at the national Green Party Congress in the autumn of 2016. Until then, there will be debates throughout the Green Party on the theme of philosophy of life and religious plurality.

What is your attitude towards religion?

The members and the electorate of the German Greens are highly diverse: you've got atheists, agnostics, Jews, Muslims, unbelievers and rather a large number of Christians, as well as people with a Christian background. As a matter of course, the latter are progressive Christians, who are critical of their church. I, myself, am a Catholic and count myself in that group. In the church people ask me about my views as a Green politician and in the Party the question is raised about how it is I can be both a Green and a Catholic, since the church discriminates against gays and does not treat women equally. There are clashes of course, although there is a huge difference between the local parish and the official views of

the Roman Catholic church. For me, the common ground between Catholic and Green lies in universalist thinking. In the church it's about people worldwide, who are all God's children, and that's a very Green way of thinking. But within all religions you'll find fundamentalist groups who believe that only a few know the truth and exclude others. Those kinds of fundamentalists will always be our adversaries. But, by and large, the great tendency in religions is universalist and that can help the Greens in our commitment to realise human rights for the whole world.

Why have the German Greens created a Commission on religion and philosophy of life?

There's been a debate about this theme for years within the Green Party, but there was no clear-cut place for it. The Greens don't have a 'C' in their name like the Christian Democrats, so we do not have a pre-arranged attitude towards religion. There was a demand from some to have a sharper separation between church and state, as well as more transparency regarding the financial inter-relationship between government and religious bodies. As a secular state, Germany has a so-called co-operative model, which means that religions have a visible role to play in the public space. That raises a lot of questions, and in addition there are a number of issues in which religious communities take a certain position as part of the public debate, as is the case in numerous bio-ethical and medical issues.

At Green Party Congresses such topics used to be rejected, often because they couldn't be linked to a certain decision and also because often they were too sensitive in society. A typical Party debate – a proposal, two counter-proposals, which are each apportioned several minutes and then a decision is made – is not a proper way for these kinds of debates. There was growing dissatisfaction that these sorts of issues were being postponed time and again. That's why the Party Executive Committee decided to set up a Commission to represent the various lines of thought in the Party on religion. Eventually, a group of 24 people with highly diverse backgrounds was selected. It has looked at the relationship between the state, the churches and non-religious denominations against the backdrop of two developments. Firstly, the on-going pluralisation of society: the number of religious and non-religious communities has increased, partly because of immigration.

Secondly, there is an increase in secularisation and individualisation, whereby people no longer feel at home in institutions. That's the reason why it is so difficult to find new rules to include all the groups.

Did the Commission use a specific definition of religion?

Due to the great differences among ourselves, we first looked for a common basis. That was an awkward task, sometimes nerve-racking and time-consuming, but once that was settled we had something to fall back on. We chose three points of departure, which were targets at the same time. Firstly, we have pledged to work towards the realisation of religious freedom as a human right in all its dimensions: the individual right to live your faith, the right to abandon your faith, and finally the collective freedom of religion. The latter point was the most controversial but, ultimately, everyone accepted that we see the religious community as a bearer of rights, since according to most religions the faith can only be lived within a community. If you see religion only as a matter of individual conscience, then that is an externally imposed notion of religion.

Incidentally, being the Chair I immediately made it clear that I, myself, am a Roman Catholic. No one is neutral when it comes to religion so, when all of us clearly show where we come from, we can talk openly. Speaking from my own experience, I can say that community is fundamentally part of religion. You can believe and pray on your own but, to live your faith in practice, you need a community. Without the collective dimension, the individual human right to freedom of religion is restricted. The decisive question here is of course: how many rights do these religious communities and their organisations have, and how can the state interfere?

The second starting point is the equal treatment of all religions and communities and the anti-discrimination principle in general, in addition to where it affects religious communities or where individuals are discriminated against by religious institutions, for example when the church is the employer.

Thirdly we've discussed the role of the communities in the society at large. Do we choose the individual as a point of departure, or do we start with the excess value of communities for the common good? We agreed it was the latter – although Greens

will always defend individual human rights including the right of self-determination. Greens set great store by a strong civic society between state and individual. If you see citizens as important actors in a vibrant democracy, then you need a strong social organisation, from a religious and a secular point of view. The image of society as a collection of autonomous individuals is not the Green vision. When we had reached common ground after months of conversations, we could start working.

How did the Commission choose its subjects?

If we wanted to keep to the arranged two-year period, we could not discuss everything. We chose themes that were socially the most relevant, themes that really affect people. These were: the church's labour law; church, state and finances; and finally the great theme of plurality.

The first two themes are typically German. As employers, the churches have lots of privileges, which can sometimes lead to discrimination. In the field of finances it's about church taxes and transparency with regard to the inter-relationship between state and church money. It's all got to do with the question whether a given group obtains the position of religious community, which is officially ordained by law, and which gives you a lot of rights, such as levying church tax. The Jews in Germany have adjusted to this system, but the Muslims have not yet done so. Every mosque in fact constitutes an independent religious community and could apply for that status. In addition, there are four Islamic umbrella groups, often organised along ethnic or national lines. We tend to see them more as political organisations. As a Commission we believe that politics mustn't intervene in the internal affairs of religious communities, even if they represent views that we find abhorrent. But what is a religious community? According to the present law, information should be given about the number of members; there should be a clearly recognisable organisational structure and a recognisable spiritual, or faith, content. Political lobby work isn't part of that.

Doesn't this kind of definition represent a western and Christian view of religion? The political and religious dimensions are already separated from one another in the definition.

Yes, that's the legacy of the Enlightenment. In Islam there is no

separation between the secular and the religious, not in this way. But we have to deal with this situation. The question was whether we opt for the abolishment of this official status. After all, it excludes some groups. Or do we plead for better access to the existing system? The latter path was chosen, partly because, in this day and age, it's not so strange to have stricter demands put on religious communities than on clubs anyone can found. In addition to this, abolition doesn't stand a political chance. But there is a widely shared will to fully take up Muslims in our society. A few smaller communities – for example, the Ahmadiyya (from Pakistan/India) and the Alevites – have acquired official status. However for the great majority of Turkish and Arabic Muslims, creative transition models are being looked into.

These already abound in education. In Germany, religious education takes place at non-religious schools. The content is shaped by the religious community and the state is responsible for the training of teachers and the loyalty to the Constitution. If you take a multiform society for granted, in which various religions have to find a way to live together – once you have said goodbye to the notion that, in future, we will all be living in a secular society in which religion doesn't play a role – then it's of the utmost importance that in schools religion is part of the discourse and the curriculum. There are a lot of experiments with ecumenical co-operation. In Berlin ethics is an obligatory subject for all, but the religious education is voluntary. There are also religious interfaith classes in some form.

The Commission also talked about the theme of plurality. How was that discussed?

As a Commission we have not been able to discuss all the new questions that this situation raises. It's not so much about legal arrangements but about the development of a different culture: do all relevant social groups get a say in the public space? For example, are all those groups represented on advisory boards in radio and television? Why aren't representatives of the secular part of society invited when it comes to organising a public commemoration after a plane crash?

As a Commission we have tried to tell precisely where policies with regard to religions apply and where they don't. In the debate about Islam, arguments with regard to religion, integration,

education and parenting, security, culture and immigration are all intertwined. Since we don't like that mixture, we have decided to talk about the politics of religion only in the strictest sense, as in the case of Muslims' rights to have their own Muslim prison chaplains or the status question. Owing to the arrival of refugees, most of them Muslims, this theme is hotter than ever.

Concerning topics like certain religious practises, we rather talked about the way in which they can and should be discussed. It's a problem that small religious communities are often not involved when it comes to talking about measures affecting them. Besides, those topics are frequently a matter of a clash between fundamental rights and you cannot just sweep one fundamental right off the table in favour of another one. In public debate that often does happen: in the discussion about ritual slaughter, animal welfare was often played off against religious freedom; in the case of circumcision, children's rights were often played off against the right of parents to raise their own children. The question is always where you draw the line. The legal principle of 'practical concordance' here is useful. It means that, in the case of a conflict between fundamental rights, you must always try to do justice to all fundamental rights in question.

In the debate about circumcision, for example, the national parliament decided that more attention should be paid to the medical risks in the training of those practising circumcision. Quite an improvement over a ban, if you ask for my personal opinion. The government decided very quickly, partly to stop any anti-Semitic and anti-Islam undertones. It was a very painful debate, within the Green Party also. And it has not come to an end with the parliament's decision, for many people still think that the perspective of the rights of children should play a bigger role.

Did the Commission look explicitly at the decision-making process within the Party?

For these kinds of sensitive subjects having to do with religion as well as for some ethical topics like assisted suicide, we have proposed a different culture of debate. It's very important to talk about it, to be able to develop a compass as a Party for these sorts of issues. Right now, the Commission hasn't adopted this proposal, but I do hope it will. It's about taking the time and space to discuss an issue across the Party, in a process whereby all the voices are

heard and experts have a say as well. Ultimately, a decision isn't taken as usual, but a picture is painted of the various opinions, to make clear where the sensitivities lie and what the dilemmas are. In such a way, you can still discuss sensitive issues, instead of shoving them through, as happened so often in the past.

Could this model be interesting for the European Green Party? At the moment it's easy to say: we're not discussing that because all the national parties can take their own view.

That might work. Owing to the many cultural differences and sensibilities, I think the EGP would never want to have a debate on religious themes if, at the end of the day, a decision will have to be taken.

Topics so narrowly linked to people's identity are very hard in the political arena. It's good to talk to one another and to have a discussion without having to take a decision. In the Commission there is a mutual understanding, without the differences having disappeared. In debates throughout the Party with members of the Commission, I hope to show that you can talk to one another despite the differences. But it takes time.

•



Afterword



All the questions in this book are related to a single one: how do you define religion? This seemingly simple question opens up a whole range of issues. For Mary White religion is “the glue that keeps communities together”, while Noël Mamère hesitates between religion as “a cross one bears in the fear of God” and “a crutch that we use to accept our finite nature”. These two examples show that the characterisation of religion itself already reveals the perspective one has with regard to religion. The definition of religion therefore is not an objective matter one can depart from, but part of the debate itself. Most social scientists writing on religion avoid a definition but, if you want to find out about the different views on religion within the Green movement, it is a very revealing question.

Green identities

For some, religion is a coherent set of ideas, held by an individual, which give meaning to life in relation to some greater good, or a higher metaphysical force. For others, it is a space which contains the rituals of family and community life, particularly those of birth, marriage and especially death. Some see religion as a collection of stories and practices dealing with the mystery of life freely, while others think of religion as something embedded in an institution. Some regard religion foremost as a spiritual experience; for others it is a bodily way of life, which concerns the way we eat, celebrate and constitute families. The choice of one of these definitions already tells something about your own secular, religious or spiritual background. Sergey Lagodinsky, for instance, experiences a clash between his being part of the Jewish community with “the Green idea of the unconditional, atomised right to self-determination from birth”, while Giorgos Dimaras sees more continuity between the ecological and religious view, since they both consider “humans as part of a whole, the universe, the creation of which surpasses the person, existing before and after the person”. For him, both ecology and religion “have an ecumenical character, and promote universal and humanistic values”.

The dialogue about religion reveals different Green identities. It shows that the Green world view is not yet coherent but contains many discrepancies, at least between different contexts in Europe. There might even be a connection between the way you look at religion and your definition of ecology and Green ideas. This would

be an interesting field of research, which could help the Greens to have a better understanding of their own ideas and world views.

It is clear that religion is found at the crossroads of identity struggles, politics, and ordinary life. It cannot be distinguished completely from other elements of culture, nor reduced to those. It is precisely these complexities that make it impossible for politics to avoid the subject of religion today.

To foster a dialogue on religion and secularism among the Greens, the presence of an open space, in which all different views on religion as well as on ecology can be articulated in an equal way, seems to be of crucial importance for a balanced debate. The question who has the power to define crucial concepts like religion, ecology and secularism needs permanent attention during this dialogue. The proposition of Bettina Jarasch in this publication about the creation of a debate across the Green Parties, without having to take binding decisions, seems valuable.

Space for minorities

When it comes to the debate on the place of religion in the public forum, the power of definition becomes even more important, since the definition one uses is linked to the answer one gives to the question: which place religion takes or should take in the public forum? Both Meyrem Almaci and Sergey Lagodinsky show that the arguments of religious minorities are given less respect and less audience than the arguments of the mainstream, which are often linked to traditional Christian values and symbols. By unconsciously defining religion in a Christian way, other religious traditions are depicted as irreligious or even wrong. In this way, says Sergey Lagodinsky, justice is not being done “to plurality and tolerance, leaving no space for others, for minorities”.

Nil Mutluer rightly states that religion is always active within a framework of power relationships. There usually is no level playing field when it comes to the relationship between religion and secularism. The Greens should be aware of this situation. Sensitivity for the arguments and experiences of others, especially minorities, is necessary, inside and outside Green Parties.

In almost all the current questions concerning religion, the relationship between the majority and minorities deserves attention. There are many issues worthwhile exploring for the Greens, such as various concepts within the Greens regarding the role of religion

in education; questions about gender and sexuality; the visibility of religion within the public forum (there are quite different views within the Greens about the hijab and even the burqa, which are seldom openly discussed); questions relating to religion and animal rights (for example, the debate on ritual slaughtering). In this last debate it is especially important to avoid falling into the trap of right-wing populist frames, who like to present this debate as a choice between the freedom of religion and animal welfare, as if Islam and Judaism are not compatible with animal welfare and there is no possibility of discussing this within those communities. To take the edge off this argument, it is vital to have relationships with leaders within religious communities and to have a minimal knowledge of the discussions within those communities. Bridges between the Greens and minority groups are therefore of vital importance in order to have a relevant dialogue on the role of religion today.

Strive for equality

One of the crucial topics between the Greens and minority groups would be the question of liberation and the equality of opportunity. For most Green Parties, equality is a core aim: all should be able to freely develop themselves. The feminist and LGBT movements have been important sources of Green politics and many Green politicians have strong ties with those movements. In the face of the shifting place of religion in our societies, however, new questions emerge, sometimes uneasy questions. Greens do not seem to have a problem accepting the presence of Islam in Europe, as virtually all interviewees show; they do not, however, always seem to be aware of – let alone agree with – concepts of equality that are debated within Islamic and migrant communities. Meyrem Almaci pleads for more differentiation in this respect: “migrant women don’t opt for the western way automatically; they use their own symbols and ways ... There is a difference in cultural strategies: you may react against some things and you make use of other things to change things within the community”. This includes the debate on the veil and the debate on homosexuality. Marco Schreuder points to visibility as the key to achieving equality, as this has been a very successful strategy for the LGBT movement in Europe. It seems vital to open a dialogue on these questions if we want to take plurality in our society seriously, to broaden the scope of Green ideas, and to find new allies within our societies.

Religion, state and society

To conduct these dialogues and conversations within and outside the Green movement in a fruitful way, it might help to have a clearer view of the different concepts in Europe regarding the place of religion within the public forum. The necessity of separation between institutional religion and the state is a clear basis for all Greens, but there are many different ways to organise this so called ‘separation’. In Greece, the need for separation is evident, but what form would fit the Greek situation best? The German Commission on Philosophy of Life, Religious Communities and the State has chosen to stick to the German co-operative model, but to make it more open to minority religious communities and to secular groups. Noël Mamère is very much in favour of the French law of *laïcité* from 1905, which ordains that the public and private spheres must remain strictly separate, but he is critical of the way in which *laïcité* is now used to exclude Muslims from French society. The motto of Judith Sargentini, ‘live and let live’, is typically Dutch since the so called ‘pacification’ of 1917. But today the limits of this practical attitude, based on compromise, are fiercely discussed.

As Noël Mamère has said, religion should not be the affair of the state; but it does play a role within society. Politicians belong to both realms, taking part in debates in which it is welcome and even desirable to clearly state your own convictions and beliefs. The state may be ‘neutral’, but this is not true for politicians nor for the political parties to which they belong. The separation between state and religion is a formal and abstract necessity, but it can never be an argument against the discussion of political questions concerning religious plurality in society.

The debate about values, religious or secular, cannot be escaped within a Europe haunted by different crises at the same time. To be able to answer the question “why are we together?”, we have to know who we are – and we are not the same as we were yesterday. Politics is not only about policies, just like Europe is not only about economics, finances and immigration rules. Let us begin to tell each other the stories of where we come from and what we long for.



Nuala Ahern and Erica Meijers — December 2015

About the Authors

- **Nuala Ahern** is a former member of the European Parliament for the Irish Greens (1994-2004). She was the first Chairperson of *Green Foundation Ireland* (2011-2014) and is currently Editor of publications for GFI. A counselling psychologist by profession, she studied psychology at Brunel University London. She has a deep interest in mythology and modern culture and is a Co- founder of the lecture series *Mythic Links*. She conducted the interviews with Mary White, Trevor Sargent and John Barry.
- **Olga Kikou** is vice President of the political Green Institute Greece for ecological thinking. She is a member of *Oikologoi Prasinoi*, the Greek Green Party since 2006 and has served in the Panhellenic Council as well as many subcommittees. She interviewed Yannis Paraskevopoulos and Giorgos Dimaras.
- **Silvia Marcon** is director of the *Fondation de l'Ecologie Politique*. She studied political science and international relations at the University of Trieste (Italy) where she graduated and holds a Master degree from the EHESS (School for Advanced Studies in the Social Sciences) in Paris. Together with Benoît Monange she interviewed Noël Mamère and François Mandil.
- **Erica Meijers** is Editor-in-chief of *de Helling*, quarterly of *Bureau de Helling*, the political foundation of GroenLinks, the Dutch Green Party, and member of the editorial board of the *Green European Journal*. She holds a PhD from the Protestant Theological University in the Netherlands. Her dissertation on the debate on apartheid in South-Africa within the protestant Churches in the Netherlands, was published under the title *Blanke Broeders Zwarte Vreemden* (2008). She was the editor of *Populism in Europe* (2011). She conducted the interviews with Meryem Almaci, Tina Walzer and Marco Schreuder, Judith Sargentini, Sergey Lagodinsky and Bettina Jarrasch.
- **Benoît Monange** works as a project manager for the *Fondation de l'Ecologie Politique*. He is a graduate of the Institute of Political Studies of Grenoble and holds a Master degree in 'Public policy and social change' from the University of Grenoble. With Sylvia Macon he interviewed Noël Mamère and François Mandil.

- **Nil Mutluer** is Head of Sociology Department at Nişantaşı University Istanbul. She is one of the founders and an elected member of the party assembly of the Green and Left Future Party in Turkey. She is also a member of the executive board of Helsinki Citizens Assembly and of the consultancy board of the Association for Supporting Women Candidates. She interviewed Savaş Çömlek.
- **Murat Özbank** teaches political theory at the International Relations Department of Istanbul Bilgi University, of which he holds a Ph.D. His most recent book is *Gezi Ruhu ve Politik Teori (Gezi Spirit and Political Theory, 2013)*. He is one of the founders and an elected member of the party assembly of the Green and Left Future Party in Turkey. He interviewed Nil Mutluer.
- **Bartłomiej Kozek** is journalist of *Zielone Wiadomości* (Green News), an eco-political magazine in Poland and member of the board of *Strefa Zieleni* (Sphere of Green), a think-tank. He has finished cultural studies at the Warsaw University. He conducted the interview with Agnieszka Kościańska.
- **Łukasz Skurczyński** is a protestant theologian and editor of *Miesięcznik Ewangelicki* (protestant monthly) and a Green Party activist. In the years 2012-2014 he was a lay reader in the Evangelical Reformed Church of Poland. He interviewed Adam Ostolski.

Imprint

Published by the Green European Foundation in cooperation with Bureau de Helling and the Green Foundation Ireland.

ISBN: 978-90-72288-58-5

All rights reserved.

Editors: Nuala Ahern (Green Foundation Ireland), Erica Meijers (Bureau de Helling).

Project coordination: Beatrice White (Green European Foundation).

Printed in the Netherlands, December 2015.

Printing: de Raddraaier, Amsterdam.

Paper: Munken Print white 100 gr (FSC).

Design: Mark Schalken (de Ruimte ontwerpers), Amsterdam.

Illustrations: Nina Mathijssen .

The opinions expressed in this book are the responsibility of the authors and are not reflecting an official position of the Green European Foundation.

This publication has been realised with the financial support of the European Parliament. The European Parliament is not responsible for the content of this project.



The Green European Foundation (GEF) is a European-level political foundation whose mission is to contribute to a lively European sphere of debate and to foster greater involvement by citizens in European politics. GEF strives to mainstream discussions on European policies and politics both within and beyond the Green political family. The foundation acts as a laboratory for new ideas, offers cross-border political education and a platform for cooperation and exchange at the European level.

Green European Foundation asbl
3 Rue du Fossé – 1536 Luxembourg
Brussels Office:

15 Rue d'Arlon – B-1050 Brussels – Belgium

Tel: +32 2 234 65 70 Fax: +32 2 234 65 79

E-mail: info@gef.eu Web: www.gef.eu





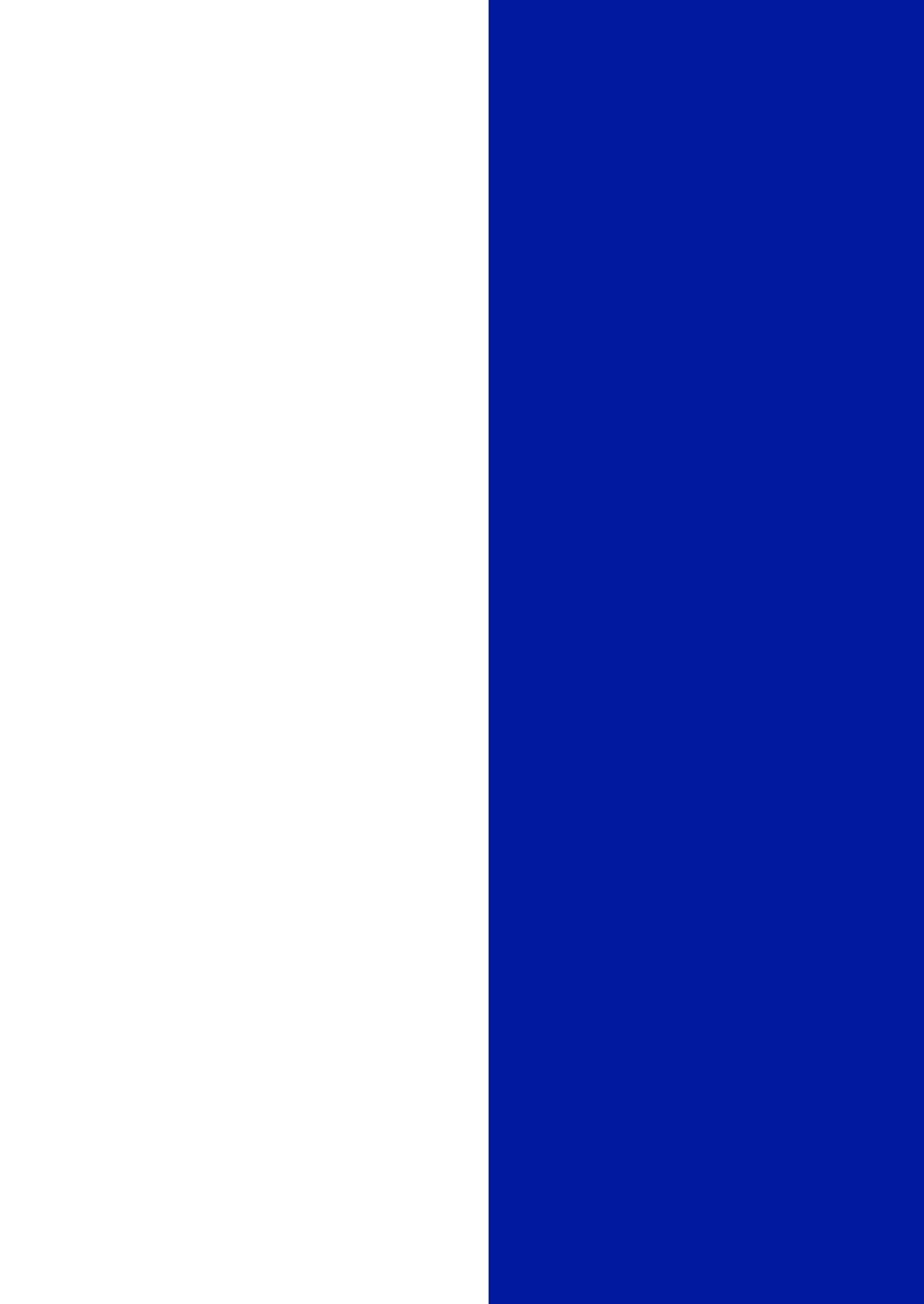



In the last decades, the relationship between religion and modern society has shifted.

As a consequence, there have been fierce debates on issues such as ritual slaughtering, homosexual teachers in schools, the wearing of the headscarf in public institutions and the relationship between Islam and terrorism.

In this publication, Green politicians from different European contexts reflect on the way their own religious or secular values influence their political attitude; the role of religion in the public forum; conflicts between fundamental rights, such as the freedom of religion and the principle of sexual and gender equality; the role of Islam in Europe and the question whether religion is a source of inspiration or an obstacle for Green politics.

Although Green parties often have an uneasy relationship with religion, the debate about values, religious or secular, cannot be escaped within a Europe haunted by many different crises at the same time. This publication is an invitation to work towards a more coherent debate within the Greens on the changing role of religion in society.



Bureau **de Helling**

